

Taal: Engels



Handleiding

Bandenbalanceerapparaat

ATH-W22 - AT 150030

ATH-W42 - AT 150031

ATH-W62 - AT 150032

MSH equipment

Appelmarkt 7

1681 PE Zwaagdijk-Oost

Tel: 0228-561100

Fax: 0228-561112

Mail: info@msh-equipment.nl

Website: www.msh-equipment.nl



ATH-Heinl

**USER´S MANUAL
ATH W42**



4500 kg





INDEX

INTRODUCTION	- 3 -
General information.....	- 3 -
General description	- 4 -
Technical data	- 7 -
Packing	- 8 -
Scope of delivery.....	- 10 -
INSTALLATION.....	- 13 -
Place of installation	- 13 -
Mounting.....	- 14 -
SETTING AND CALIBRATION	- 21 -
System setting	- 21 -
Calibration of piezo transducer	- 22 -
OPERATION	- 25 -
Operation instruction.....	- 25 -
Safety instructions.....	- 26 -
Utilization	- 27 -
MAINTENANCE	- 35 -
Error and remedy.....	- 35 -
Troubleshooting	- 36 -
Maintenance and service instructions	- 37 -
DECLARATION OF CONFORMITY	- 38 -
WARRANTY NOTE.....	- 39 -
SPARE PART BOOK	- 41 -
Machine	- 42 -
Display	- 44 -
Accessory	- 45 -
Hood Mounting	- 46 -
Hood.....	- 47 -
Motor	- 48 -
Main shaft	- 49 -
Sensor	- 50 -
Encoder.....	- 51 -
Brake	- 52 -
Power board	- 54 -
Distance arm	- 55 -
Laser.....	- 57 -
Computer board.....	- 58 -
NOTES.....	- 59 -

INTRODUCTION

General information

	<p>THIS MANUAL IS AN INHERENT PART OF THE MACHINE. IT MUST BE READ AND UNDERSTOOD FROM THE OPERATOR. THERE IS NO RESPONSIBILITY FOR DAMAGES, WHICH ARE RESULTING FROM NON-OBSERVANCE OF THIS MANUAL OR THE GUILTY SAFETY REGULATIONS.</p>
---	--

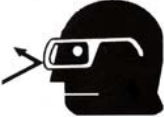

	<p>ATTENTION: Follow the instructions to avoid injuries or damages.</p>
---	---

	<p>TIP: Gives further information's to the functions and tips for using the machine efficiently.</p>
---	--

	<p>Protective clothes must be worn for all works on the described machine.</p>
--	--

Name plate:

	<p>Note all information's regarding the tire changer into the following gaps. It is forbidden to remove the name plate from the tire changer.</p>
---	---

		<p>ATH-Heinl GmbH & Co.KG Kauerhoferstr. 2 - 92237 Sulzbach-Rosenberg - GERMANY</p>		
<div style="background-color: #cccccc; height: 28px;"></div>				
Typ Type	<div style="background-color: #cccccc; height: 43px;"></div>	Volt	<div style="background-color: #cccccc; height: 43px;"></div>	
Serien # Serial #	<div style="background-color: #cccccc; height: 43px;"></div>	Ph	<div style="background-color: #cccccc; height: 43px;"></div>	
Baujahr Year of built	<div style="background-color: #cccccc; height: 43px;"></div>	Amp.	<div style="background-color: #cccccc; height: 43px;"></div>	
		kW	<div style="background-color: #cccccc; height: 28px;"></div>	
<p>Assembly in China implemented by ATH Co. Ltd. Shanghai</p>				

General description





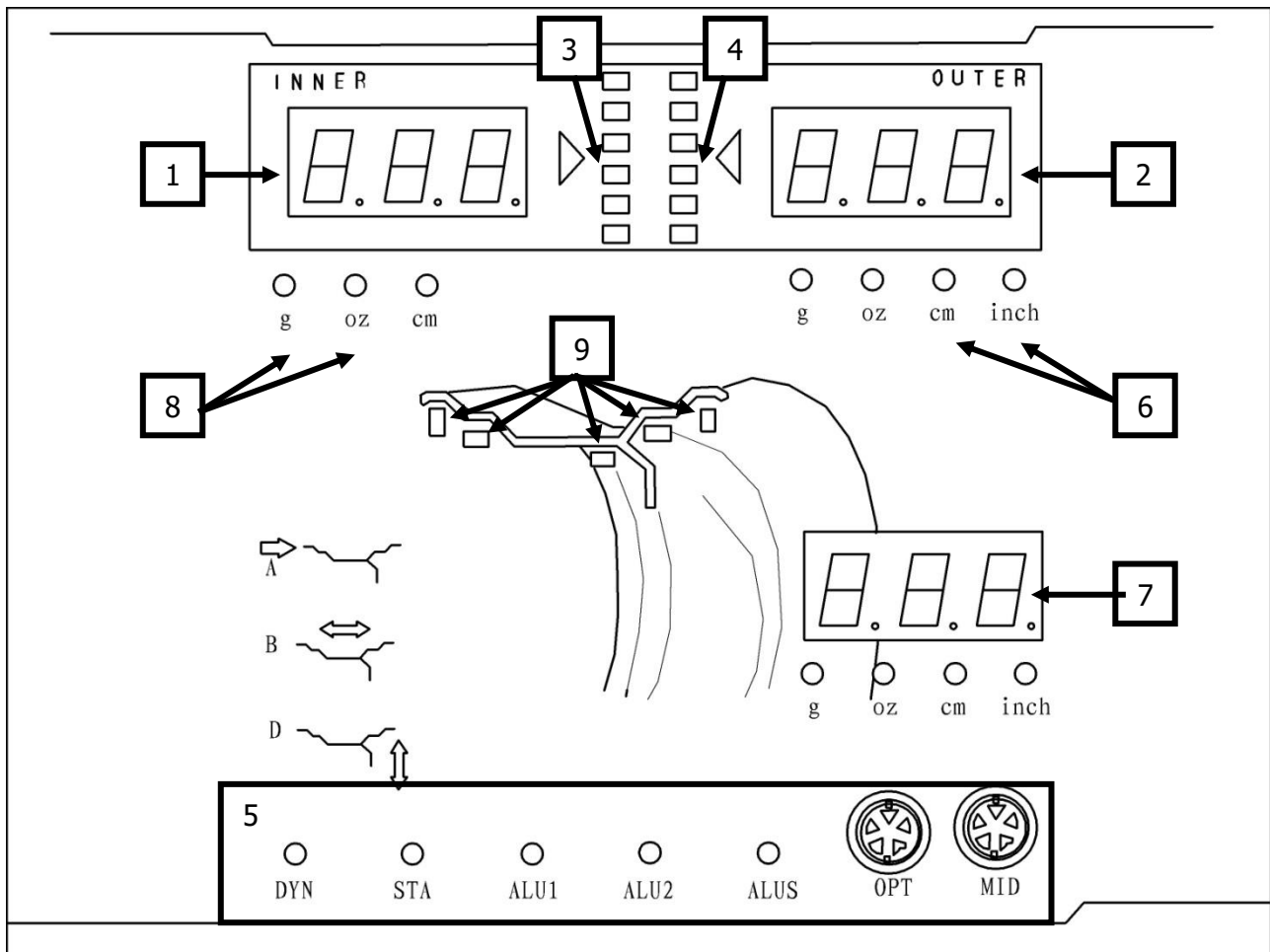



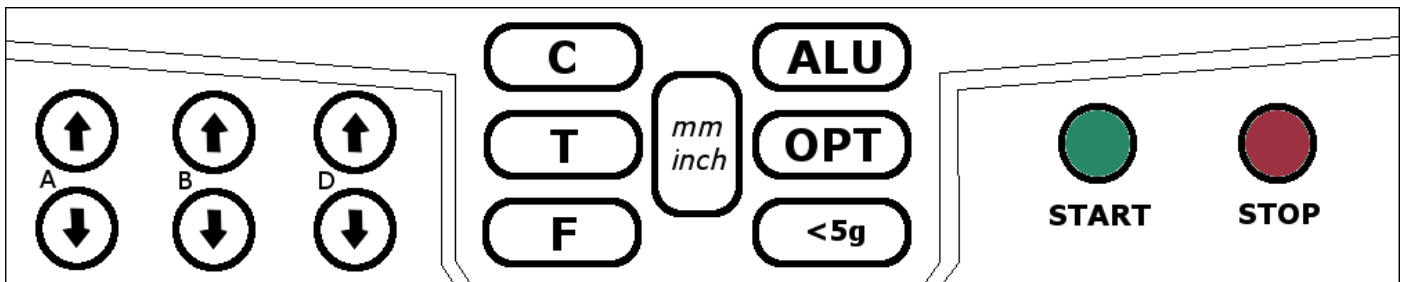







1. Main switch with emergency stop function for switching on and off
2. Cone holder
3. Weights rack
4. Protective bow
5. Measuring device
6. Balancing shaft
7. Display
8. Operation panel
9. Brake pedal
10. Rim width measuring device (optionally)



1) Display INNER unbalance	2) Display OUTER unbalance
3) Indicator: Position of INNER unbalance	4) Indicator: Position of OUTER unbalance
5) Mode indicator	6) Indicator lamp for measuring unit mm or inch
7) Display unbalance STATIC	8) Indicator lamp for measuring unit g or Oz
9) Indicator for weight position	

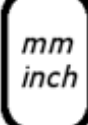

  Distance rim to machine	  Rim width	  Rim diameter
 Calibration button	 Self-test	 Switchover DYNAMIC/STATIC
 ALU program selection	 Optimization program	 Display of exact unbalance <5g
 Switchover for input parameters	 START -button	 STOP -button



Do only use your fingers for operating the machine. In no case use sharp objects.

Technical data

Maximum wheel weight	< 65 kg
Rim diameter	12 - 24 inch
Rim width	1,5 - 20 inch
Maximum wheel diameter	800 mm
Balancing accuracy	+/- 1 g / 0,1 Oz
Accuracy of measurement	>99%
Cycle time	7 - 12 s
Motor	0,25 kW
Power supply	1/220V/50 Hz
Power consumption	<15W in standby
Revolutions per minute	180 rpm
Protection type	IP 54
Noise level in operation	<70 dB(A)
Shaft diameter	40 mm
Balancing programs	Mode "Dynamic" (Standard) Mode "Static" Standard "ALU-1", "ALU-2" -Mode Mode "ALU-S"
Additional functions	OPT (Optimization) –Mode HID (weight positioning behind spokes) – Mode Setting of measuring units in g / Oz, mm / inch
Anchoring	Bolt anchors: M8 x 100
Quantity anchors	3 pieces
Dimension (L x W x H)	approx. 1330 x 800 x 1700 mm
Net / Gross weight	113 / 176 kg

Packing

Check the delivery in presence of the forwarder.

! Check the goods for visual damages. If something is missing in the scope of delivery (see packing list) note it on the forwarder's documents and inform your distributor (also in case of visual damages). If there is a damage or if goods are missing refuse delivery, note it also on the documents and inform your distributor.

Instructions for transport and storage:

- Lift with care, using suitable means of support for the load, in perfect working order.
- Avoid sudden jolts and tugs, watch out for uneven surfaces, bumps etc.
- After removing the packing, check that they are taken to special waste collecting areas inaccessible to children and animals as long as they are not disposed.
- Warehouse temperature: $-10^{\circ}\text{C} \sim +60^{\circ}\text{C}$
- Air humidity: 20%-95%

Dimension	
H	1.160 mm
T	980 mm
B	790 mm

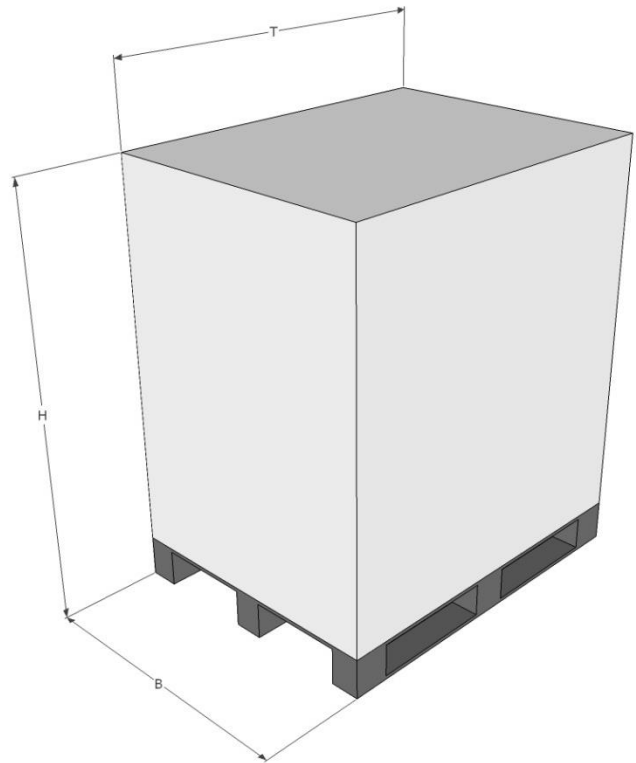

The attached picture shows the content of package.



Additionally, there is an accessory package
INSIDE the balancing machine.
To get access to this package you must tilt the
machine slightly and take the carton.

If anything is missing in the delivery (see
packing list), contact our sales department.





Scope of delivery

Wheel guard
Consists of two plastic bows and a frame with handle



LED Monitor with support

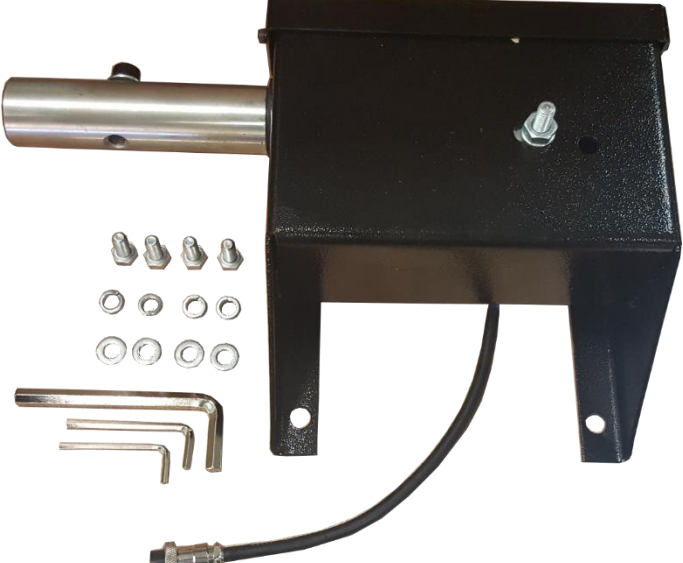

<p>Rim measuring gauge Measuring range diameter: 10 - 23 inches Measuring range width: 3 - 14 inches Packing dimensions: 455 x 430 x 50 mm</p>	
<p>Wheel guard mechanism screw for wheel guard Packing dimensions: 350 x 230 x 160 mm</p>	
<p>Accessories box Packing dimensions: 385 x 240 x 280 mm</p> <p>Stick-on counterweight remover Clip-on counterweight 5g Clip-on counterweight 10g Clip-on counterweight 35g Clip-on counterweight 50g Clip-on counterweight 100g Weight plier Hex keys Cup for quick nut Rubber lip for cup of quick nut Tension spring Anchor bolts</p>	

Balancer shaft
Screw for shaft
Quick nut
Cone 45 – 75 mm
Cone 70 – 90 mm
Cone 88 – 110 mm
Cone 105 – 130 mm
Adaptor-Ring for big cone 105 – 130 mm



INSTALLATION

Place of installation

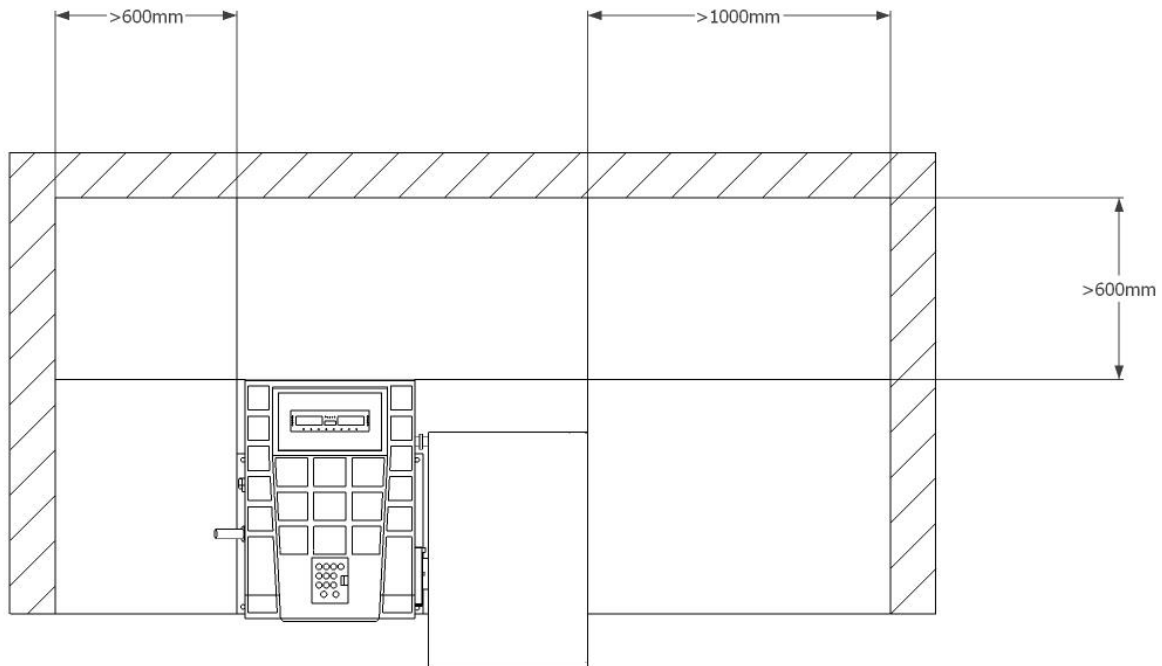

Admitted operation temperature:	0-50 °C
Maximum admitted air humidity:	≤85% at 30 °C
Height over sea level:	≤1000m
Power connection and ground cable (see technical data) could be made in form of plug device (socket and plug) or a fixed connection.	
Necessary supply lines:	see technical data

⚠ The installation of the machine is **not allowed** in **wet** rooms as well as in rooms with a **risk of explosion**.

Mounting

 This manual is **not** to be mounting instructions but only as a help for skilled technicians. For the following works, suitable clothes must be worn and individual safety devices must be made. An incorrect mounting and setting excludes warranty and liability.

1. Mounting of the wheel balancer

- a. Lift the wheel balancer from the pallet, use hereby solely the intended support points. In no case lift the machine at other points as e.g. the shaft, the display or the accessory plate.
- b. The machine must stand firmly on the floor at the intended support points, if necessary there must be used washers.

2. Fixing with security anchors:

- a. Bore holes, pay attention in doing so to the necessary boring depth A and the boring diameter of the anchor manufacturer

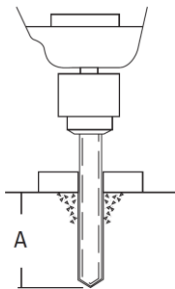

- b. Clean the inner of the holes

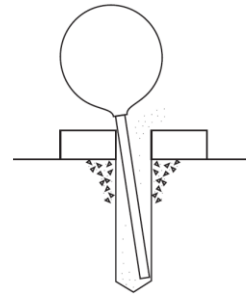

- c. Put the anchor bolts into the holes until you reach the bottom of the hole.

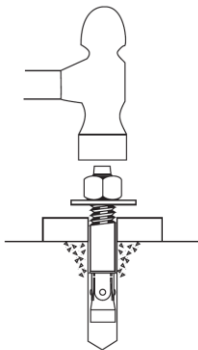

- d. Tighten the nut with the necessary torque specified by the manufacturer. Clamping thickness B depends on flooring.

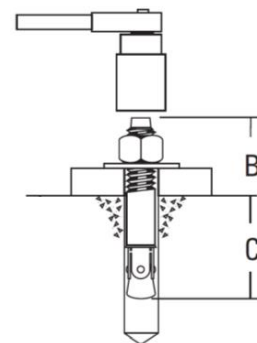

 The wheel balancer must be fixed firmly on the floor for achieving an exact balancing result.

3. Mounting of balancing shaft

Clean the adaptor before mounting the balancing shaft



!!! Before fixing it must be payed attention to that both markings fit together!!!



Now fix the balancing shaft to the clamping cup with the attached screw.



4. Mounting of protective bow

Remove the top cover of the wheel cover mechanism.
Fix this by using the four attached screws, washers and spring rings on the machine.

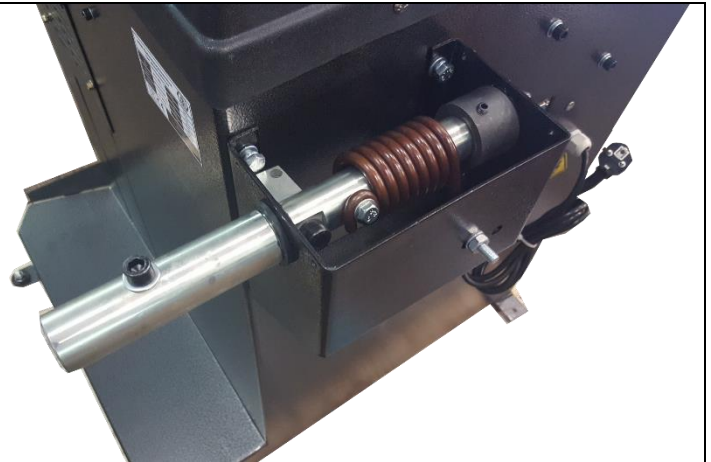

Connect the mechanism on the machine and attach the top cover.

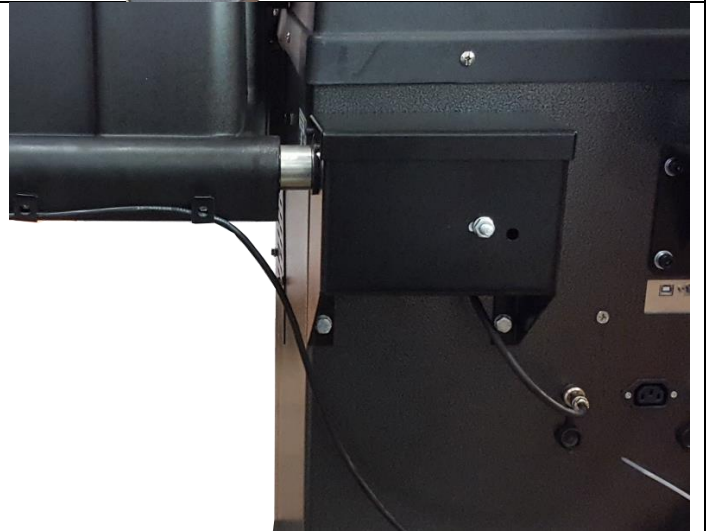

Remove the handle bar on the frame of wheel cover.
Remove the screw for fixing the frame on the wheel cover mechanism.



Place at first the back part of the wheel cover on the frame of the wheel cover.

After this place the complete part on the shaft of the wheel cover mechanism.



Place now the front part of the cover on the frame

Connect the both parts and fix them by using the attached screws.

Fix the complete wheel cover with the screw on the main shaft of the wheel cover mechanism.

Add again the handle bar on the frame.



5. Installation of the display

Fix the support of display by using the four attached screws on the machine body.

Remove the top two screws of the cover to add the cables into the cable canal.

Connect now the cables on the machine.



Fix the monitor on the support by using the attached screws.

Connect the cables with the display.

At the end add again the both screws of the cover.



6. Installation of wheel width measuring device (optional)

First mount the holder of the arm on the frame of the protective bow.



Now fix the measuring gauge with two hexagon socket screws on the frame of the protective bow.



Now fix the connection cable with wire straps on the frame...



...and connect it following on the middle connection of the machine.

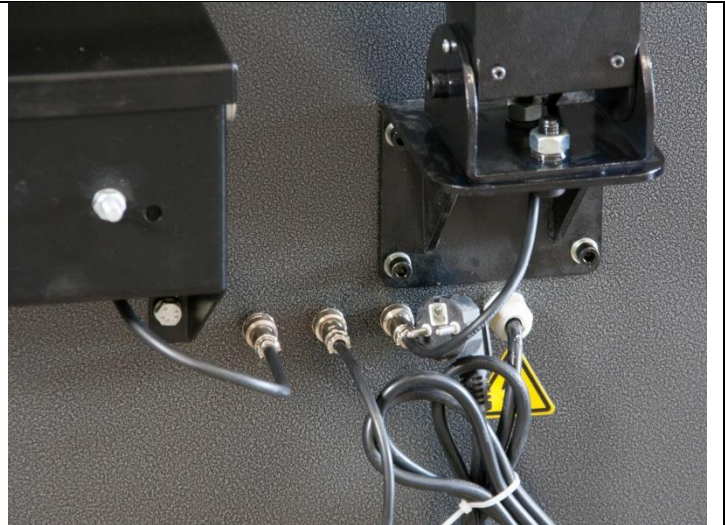

7. Activate the width measuring gauge

To get access to the settings you must use the shown procedure.

1. At first push the C-Button after this push additionally the T-Button
2. Now the display shows CAL – CAL and the indicator light are flashing.
3. Release both buttons after the indicator lights are steady on.
4. Push the A↓ Button
5. Push the A↑ Button
6. Push the ALU Button
7. Push four times the A↑ Button

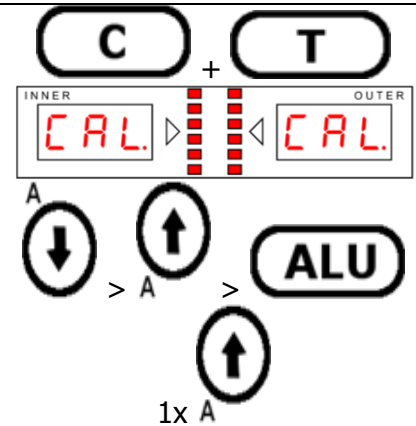

Now you can turn on or off the function of the measuring gauge with B↓; B↑ buttons.

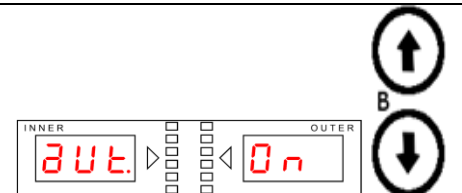

For finish the progress you must push four times the A↑ button

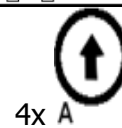

8. Electrical connection





 Here, the general and local regulations must be observed. Therefore, this step must be performed only by an expert. Pay attention to the correct current supply. (see technical data).

 The main connection cable of the machine is to be fitted with a plug that meets the appropriate standards. If the machine is connected directly (without plug), it is recommended to secure the circuit breaker for the balancing machine with a padlock, so that only the appropriate personnel have access. Connect the machine with an own connection and an own suitable circuit breaker.

SETTING AND CALIBRATION

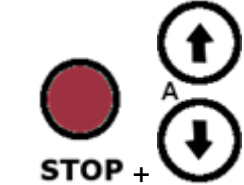
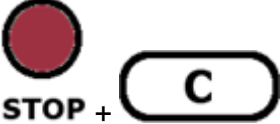
System setting

By means of the system setting the basic settings can be determined.

Display of unbalance g / Oz	
Automatic start when closing the protective bow on / Out	
Calibration of automatic measuring device (2D)	
Calibration of second automatic measuring device (Optionally 3D)	
Calibration program	
HID program	

Calibration of piezo transducer

The machine **MUST BE** calibrated after the fixing and minimum before the season or after a longer standstill.

Clamp an already balanced wheel (14" or 15") and input the parameters (see Utilization, item 4).

For getting into the calibration system you must press the adjacent key combination:

1. First press the button C and then additional the button T
2. Now appears in the display [CAL] – [CAL] and the indicators are blinking
3. Release the buttons only when the indicators are blinking regular.

By pressing the button START or closing the protection bow the balancing cycle for the calibration will be started.

After the balancing cycle appears the adjacent display.
Position the calibration weight (100g) on the INNER side of the rim.

By pressing the START button or closing the protection bow the second balancing cycle for the calibration will be started.

After the balancing cycle appears the adjacent display.
Position the calibration weight (100g) on the OUTER side of the rim.

Press again the button START or close the protection bow for finishing the calibration.

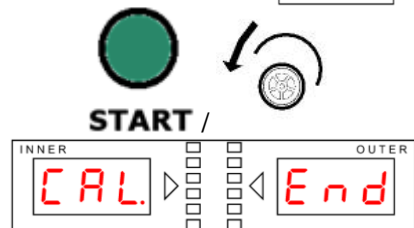
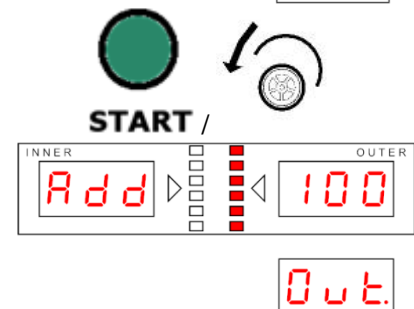
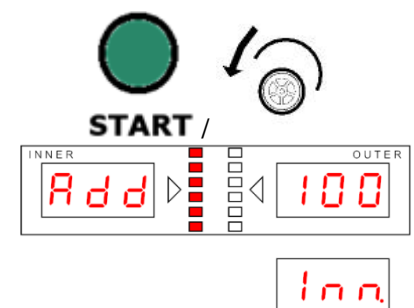
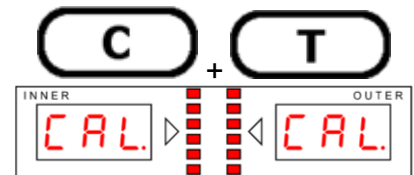

Service calibration of measuring gauge

1. Place the measuring gauge on the position „0“
2. Press the key combination STOP + <5g
3. Afterwards the adjacent display appears

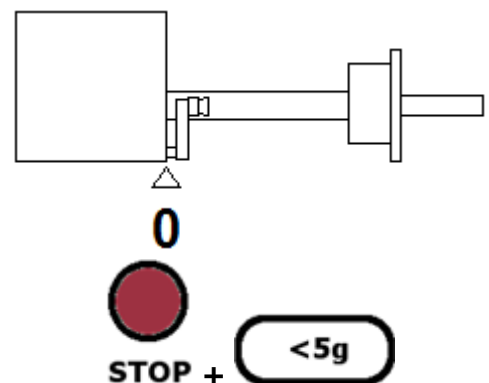

4. Place the measuring gauge on the position "100mm"
5. Press the button ALU

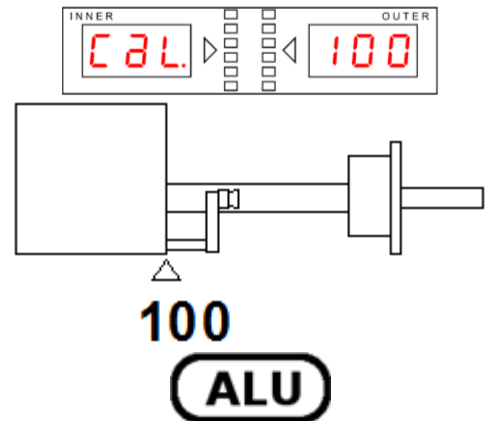

6. In the display appears [CAL] – [215]
7. Place the measuring gauge on the position "215mm". Hereby you must take the head of the measuring gauge on the bowl of the balancing shaft.
8. Press the button ALU

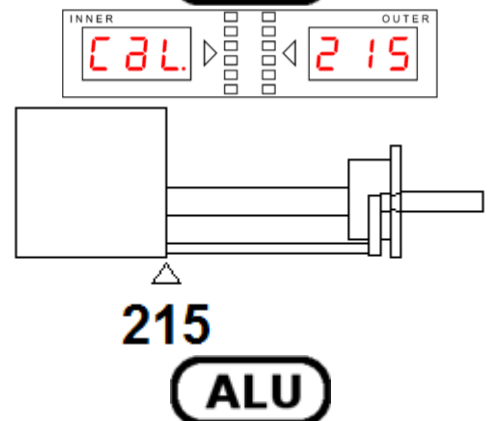

9. In the display appears [CAL.] – [15.0]
10. This parameter can be changed with D+ / D-
11. Following confirm with ALU button
12. Clamp now a corresponding wheel (e.g. 16") on the machine
13. Place the measuring finger on the edge of the rim
14. Press the button ALU

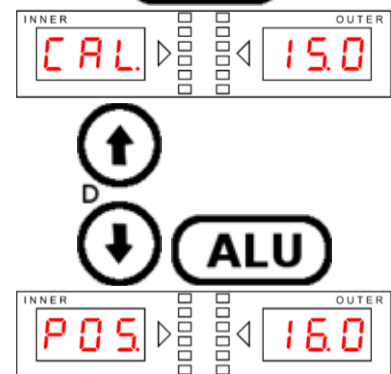

15. In the display appears [CAL] – [End]
16. If [CAL] – [10] appears then the calibration is failed and must be made again.



Service calibration of width measuring gauge (optionally)

1. Press the key combination STOP + OPT
2. Then the adjacent display appears

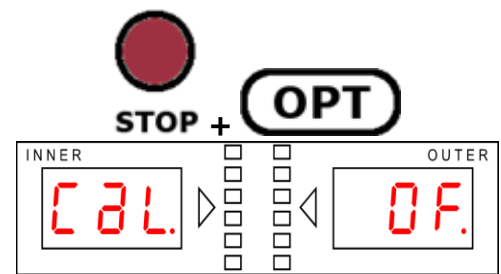

3. Place the width measuring gauge on the clamping hood
4. Press the button ALU

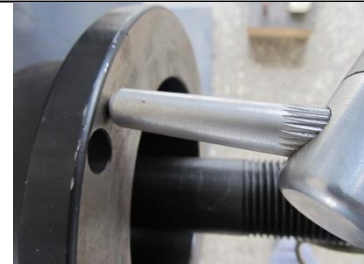

ALU

5. In the display appears [CAL] – [200]
6. Now take the distance holder and place it on the clamping hood
7. Now put the width measuring gauge on the end of the distance holder
8. Press the button ALU



ALU

9. In the display appears [CAL] – [End] and shows with this the correct calibration
10. If [CAL] – [OF] appears the calibration is failed and must be made again.

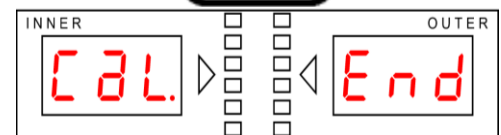

It is recommended that the ALU S program the display threshold to 10 g adjust.

Why:

- Since the machine determines the dynamic and static imbalance, the running property of the wheel is changed in the weight attachment.
- Since the weights are further positioned in the centre of the rim, this automatically larger the more correct balancing results are to succumbing.
- Since the machine requires the balancing weights at one point and there are different adhesive weight systems, this can cause a large weight spread.
- The adhesive weights are not mounted 100% at the required location.

OPERATION

Operation instruction

WHEEL BALANCER

RISKS FOR HUMAN AND ENVIRONMENT



- Risk of tilting or slipping of the machine
- Risk of slacked wheels
- Risk of flying away dirt or dust particles
- Risk of loose hanging clothing or long hair
- Trip hazard and falling
- Hardness of hearing by hurtful noise
- Disease of the backbone by lifting and carrying heavy loads

PRECAUTIONS AND RULES OF CONDUCT



- Ensure proper stability
- Wear personal protective clothes:
Safety shoes,
Protective goggles and gloves,
ear protection
- Put protective device in operation
- Use proper adapters
- Clean the wheel from dirt (wet cleaning, do not use compressed air!)
- Wear close-fitting working clothes, possibly with Velcro fastener on arms and legs
- Protective cap for long hairs
- If possible, use transport devices and lifting devices and transport in pairs
- Pay attention to an ergonomic workplace design
- Right lifting and carrying for the backbone

BEHAVIOUR IN CASE OF ERROR

- In case of security relevant errors stop immediately the operation and secure it against use
- Inform responsible person in case of defects
- Do not make any alterations/changes on the machine!

FIRST AID



Emergency call:

- Keep in mind in case of an accident not only to save the injured person and to render first aid but also to secure the scene of accident.
- Report every accident immediately to the responsible person.
- Place of first aid kit and first aid book: _____
- Record all information in the first aid book.

MAINTENANCE, DISPOSAL

Reparations are only allowed to be made by the after sales service of the manufacturer.

Safety instructions

- Only skilled persons can operate the machine.
- If the operator makes unauthorized alterations and/or changes on the machine the CE verification is invalidated and ATH-Heinl is excluded from liability for damages resulting from such alterations and/or changes.
Safety devices are not allowed to be removed or to be taken out of operation
- Only use the machine according to its intended and specified use.
- As there is always a residual risk which cannot be foreseen while working with technical work equipment, there are different self-explanatory warning symbols on the balancing machine. This warning symbols signalize the operator a possible residual risk and shall provoke a special care to avoid accidents and/or damages of the product to be treated.
- In general, the operator shall eliminate possible residual risks before by a proper and careful attitude.
- Always use correct and proper working materials.
- Wear suitable protective clothing respectively protective agents (e.g. protective glasses, ear protection, safety shoes and so on).
- Consider given information, instructions and technical data of the machine producer respectively of the manufacturer of the product to be treated.
- Power-operated wheel balancing machines are only allowed to be used in Germany with a protection bow.
- Do not use compressed air when cleaning the machine.
- Clean plastic surfaces with alcohol (do not use solvent cleaner).
- It must be paid attention to that the wheel is clamped fix on the adapter before beginning the balancing process.
- The operator must pay attention to that there are no other persons in the danger zone during the balancing process.
- Do not put big objects on the machine as this could affect the accuracy of the balancing result.

Further safety instructions in detail are indicated in the single chapters.

Utilization

1. Self-diagnostic

After switching-on the machine makes a self-diagnostic and changes then automatically into the mode „Dynamic“

2. Mounting the wheel

Choose a suitable cone to centre the wheel on the balancing adaptor.
As shown below there are 2 simple possibilities to clamp the wheel.

a. The first possibility for centering is as shown adjacent.
Here the rim will be clamped with a cone from outside on the balancing shaft.

When using the biggest cone must be used additionally the adaptor for the clamping hood.



This possibility increases the danger of clamping errors and is only recommendable for steel rims.

b. At the second possibility, first the tension spring and then a suitable cone will be placed on the balancing shaft. With a clamping hood, the rim can be clamped on the balancing shaft.

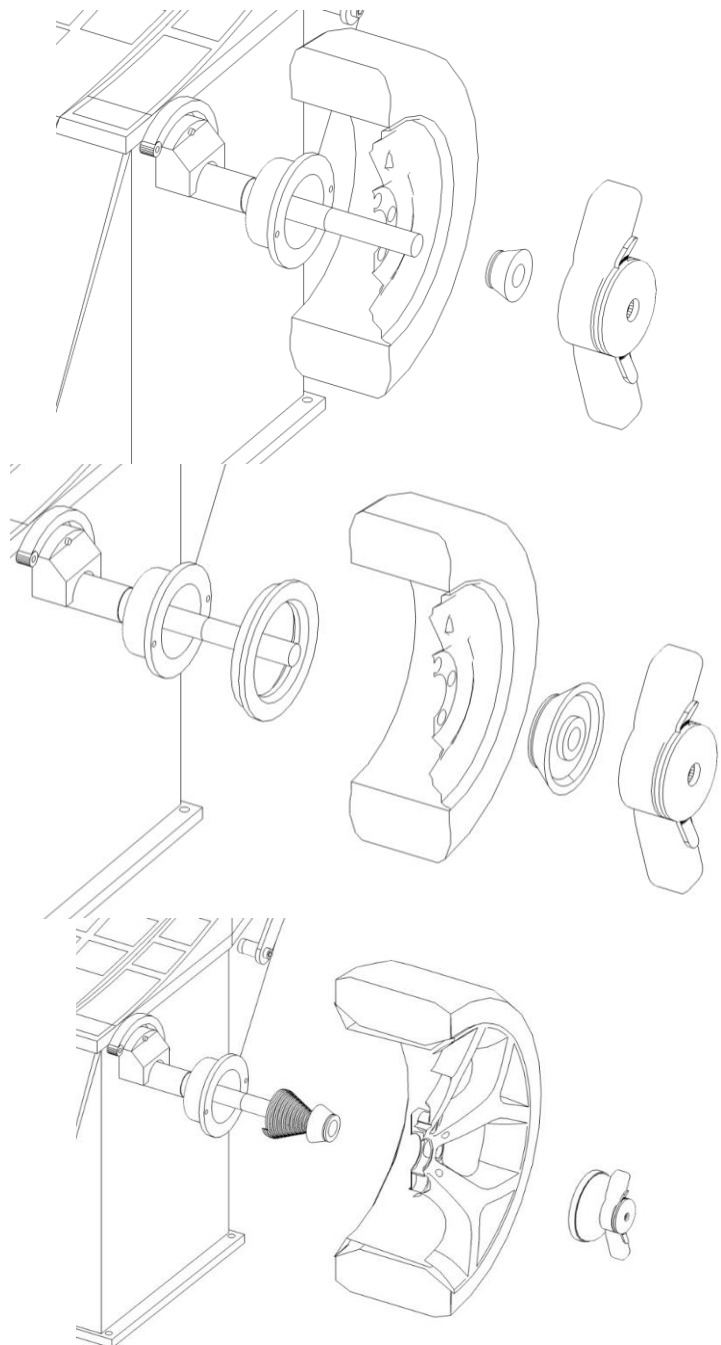

3. Choose of balancing mode

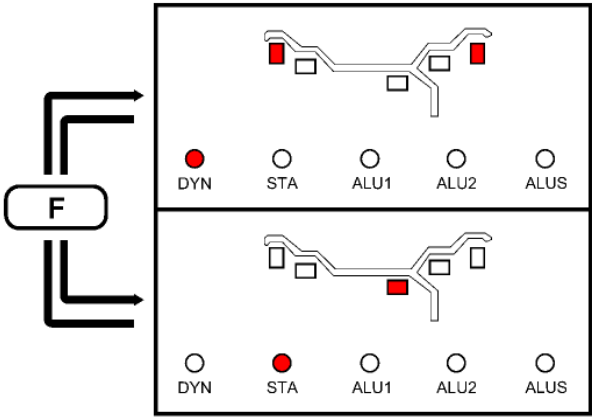
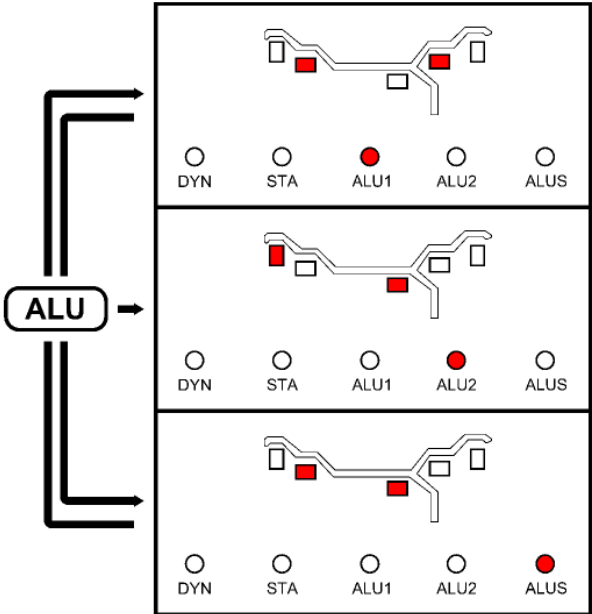
<p>DYN Dynamic – Mode (Standard): This function determines the radial and lateral runout of a light alloy or steel rim. The balancing weights will be placed on the outer and inner side of the clamped wheel.</p>	
<p>STA Static – Mode: This function determines the radial runout of a steel rim. The balancing weights will be placed on a central position of the rim.</p>	
<p>ALU -1- This function determines the radial and lateral runout of a light alloy rim. The balancing weights will be placed on predefined points.</p>	
<p>ALU -2- This function determines the radial and lateral runout of a light alloy rim. The balancing weights will be placed on predefined points.</p>	
<p>ALUS This function determines the radial and lateral runout of a light alloy rim. The balancing weights will be placed on points, predefined by the operator.</p>	



For balancing of light alloy rims, we are recommending the ALU S mode. This mode considers not only the cross section of the rim but also helps at the exact positioning of the adhesive weight.

At ALU 1 there must be observed the following measurements while positioning the adhesive weights:

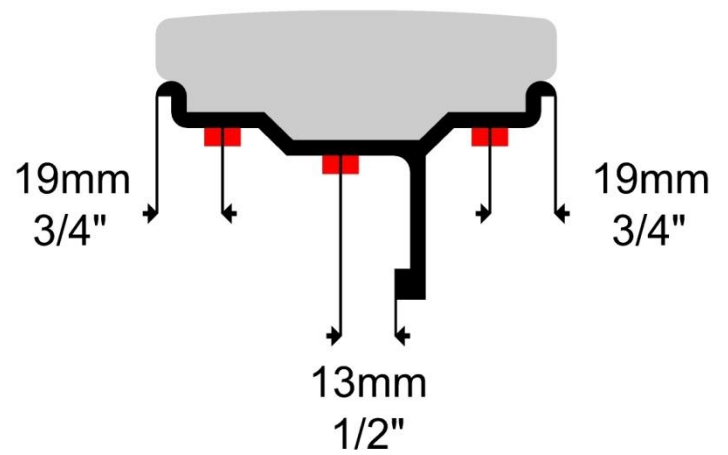
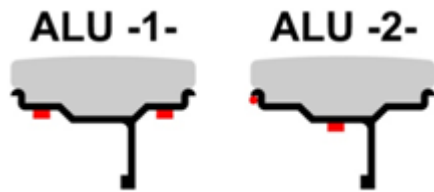

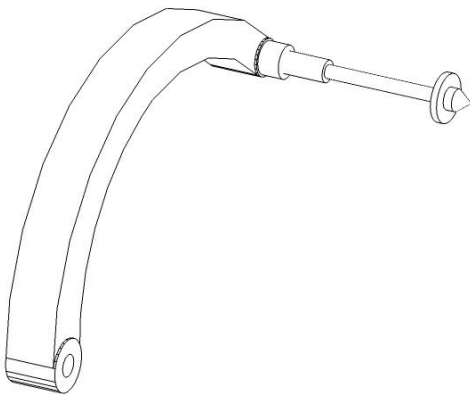

4. Input of wheel parameters
a) Basically:

In the motorcycle mode must be used an optional test prod (+100 mm).

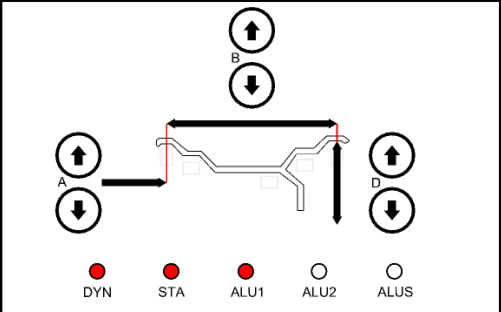

b) Wheel parameters and input for calculating the unbalance:

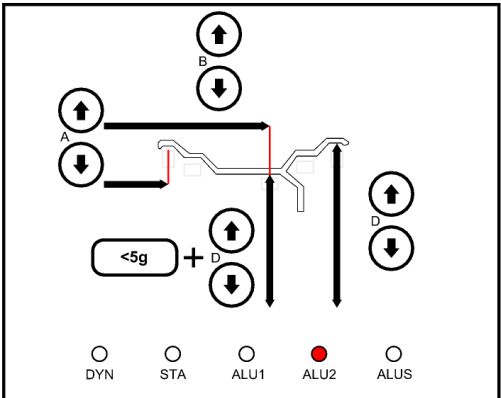
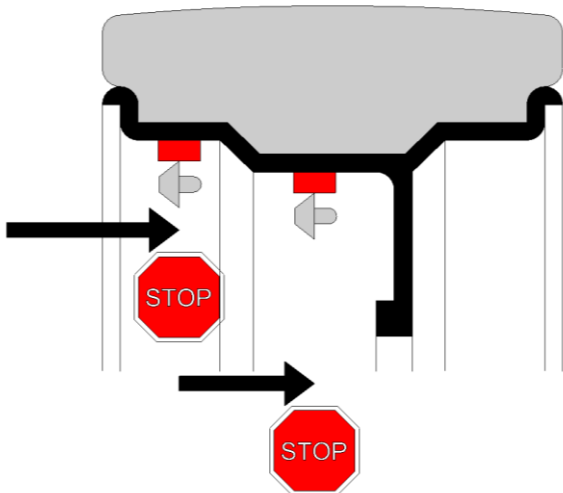
<p>In the modes DYN, STA and ALU1 the following data must be entered: [A] Distance from wheel to machine [B] Rim width [D] Rim diameter</p>	
<p>Input the values by place the measuring gauge on the rim. In doing so the machine stores automatically the data of [A] and [D]. Now the rim width must be entered with the buttons [B+] / [B-].</p>	
<p>In the mode ALU2 and ALUS the following data must be entered: [A] Distance from machine to first weight position [B] Distance from machine to second weight position [D] Rim diameter [dE] Rim diameter on the point for the weight</p>	
<p>In the measuring process, first the measuring gauge should be moved to the first point, after a short while it can be moved to the second point. In doing so the machine stores automatically the data [A]; [B]; [D] and [De]. ATTENTION: The program ALUS don´t must be selected before entering the parameters.</p>	

Starting balancing process

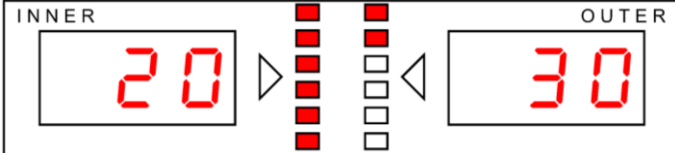
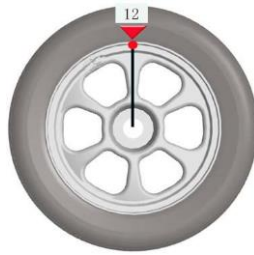
<p>Starting of the balancing process by pressing the button START or closing the protection bow.</p>																			
<p>Turn the wheel until all diodes in the display illuminate.</p>																			
<p>Now the weight must be placed on the wheel. The machine offers you the following help for the exact positioning:</p> <table border="1" data-bbox="108 869 770 1473"> <thead> <tr> <th>Program</th> <th>Internal weight</th> <th>External weight</th> </tr> </thead> <tbody> <tr> <td>DYN</td> <td>Position 12 o'clock (Laser)</td> <td>Position 12 o'clock</td> </tr> <tr> <td>STA</td> <td colspan="2">Position 12 o'clock (Laser)</td> </tr> <tr> <td>ALU1</td> <td>Position 12 o'clock (Laser)</td> <td>Position 12 o'clock</td> </tr> <tr> <td>ALU2</td> <td>Position 12 o'clock (Laser)</td> <td>Weight taking on the measuring arm</td> </tr> <tr> <td>ALUS</td> <td>Weight taking on the measuring arm</td> <td>Weight taking on the measuring arm</td> </tr> </tbody> </table>	Program	Internal weight	External weight	DYN	Position 12 o'clock (Laser)	Position 12 o'clock	STA	Position 12 o'clock (Laser)		ALU1	Position 12 o'clock (Laser)	Position 12 o'clock	ALU2	Position 12 o'clock (Laser)	Weight taking on the measuring arm	ALUS	Weight taking on the measuring arm	Weight taking on the measuring arm	
Program	Internal weight	External weight																	
DYN	Position 12 o'clock (Laser)	Position 12 o'clock																	
STA	Position 12 o'clock (Laser)																		
ALU1	Position 12 o'clock (Laser)	Position 12 o'clock																	
ALU2	Position 12 o'clock (Laser)	Weight taking on the measuring arm																	
ALUS	Weight taking on the measuring arm	Weight taking on the measuring arm																	

a) HID-Function

With the HID function, it is possible to hide the external balancing weight behind the spokes. This function is available in the modes ALU2 and ALUS.

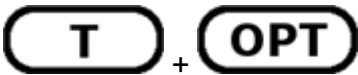
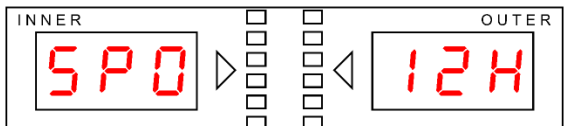

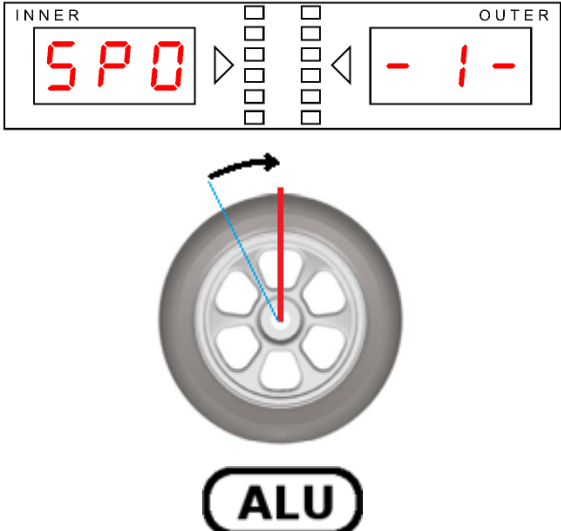
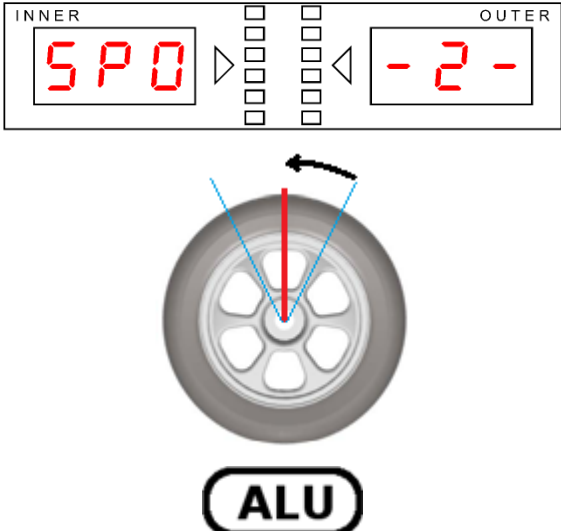
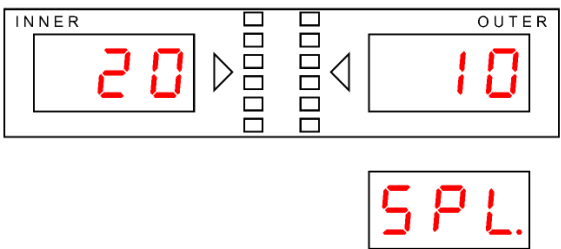
<p>After the balancing procedure, the HID-Function can be start by pressing the buttons T + OPT</p>	
<p>After this appears in the display SPO – 12H. Turn now the wheel until all diodes for the outer position illuminates. Confirm now this position with ALU.</p>	

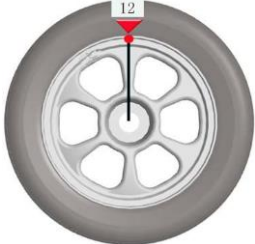
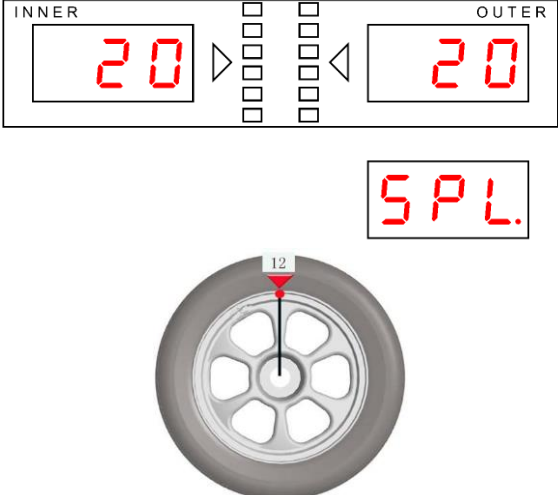



	
<p>After this appears in the display SPO – -1-. Turn now the wheel until the left spoke are at the position 12 o'clock. Confirm now this position with ALU.</p>	
<p>After this appears in the display SPO – -2- . Turn now the wheel until the right spoke are at the position 12 o'clock. Confirm now this position with ALU.</p>	
<p>After this the INNER UNBALANCE will be shown in the display and below of it SPL. By turning the wheel until all diodes for the OUTER position illuminate, the corresponding value will also be displayed.</p> <p>Now place the weight on the measuring gauge and put it by means of it on the rim.</p>	

	
<p>Turn the wheel further until all diodes illuminate again for the outer position for localizing the second value, in doing so the corresponding value will be displayed.</p> <p>Now place the weight on the measuring gauge and put it by means of it on the rim.</p>	

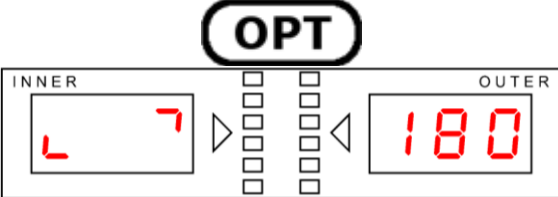
b) Optimization

With this OPT function it is possible, to minimize the static unbalance of the wheel. Thereby the unbalance of the rim will be balanced with the unbalance of the tire.

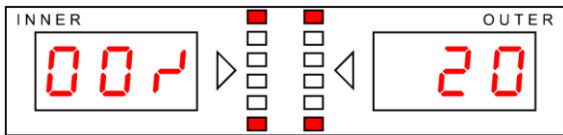
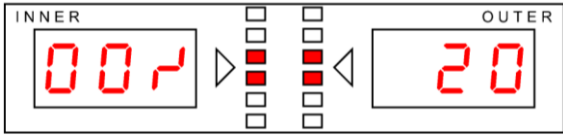
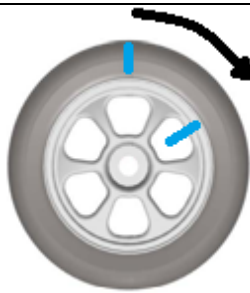
<p>After the balancing process, you can check the static unbalance by pressing the button.</p> <p>By an unbalance over 30 g it is recommendable to make an Optimization.</p>	
<p>Mark at the position of the valve the tire, the clamping cup of the wheel balancer as well as the rim so that the marking is in one line with the valve.</p> <p>Now turn the wheel until the valve is at the position 12 o'clock.</p>	
<p>For starting press the button OPT.</p> <p>After that the program shows that the customer must turn the tire by 180° on the rim.</p>	
<p>Remove the wheel from the wheel balancer.</p> <p>Measure the air pressure and demount the tire with a suitable tire changer.</p> <p>Mount the tire again on the rim, in doing so it must be turned through 180°.</p> <p>Fill the tire with the same air pressure.</p>	

<p>Following the wheel can be clamped again on the wheel balancer, in doing so pay attention to the marking on the clamping cup.</p>	
<p>Starting of the balancing process by pressing the button START or closing the protection bow.</p>	
<p>After this you will see the possible optimization.</p> <p>After this turn the wheel on the machine until the displays show the attached figure.</p> <p>Now you must mark the TIRE on the 12 o'clock position.</p>	
<p>After this turn the wheel on the machine until the displays show the attached figure.</p> <p>Now you must mark the RIM on the 12 o'clock position.</p>	
<p>Remove the wheel from the wheel balancer. Measure the air pressure and demount the tire with a suitable tire changer. Mount the tire again on the rim hereby both lines of tire and rim must match in one line. Fill the tire with the same air pressure. Following the wheel can be clamped again on the wheel balancer.</p>	
<p>Starting of the balancing process by pressing the button START or closing the protection bow.</p>	

MAINTENANCE

Reparation works are only allowed to be done by authorized service partners or, after consulting ATH, by the customer.

 Before maintenance and reparation works the machine must be switched off from the power supply. (Main switch off, disconnect plug). There must be taken measures against switching on.

Works on the electrical parts respectively the supply lines are only allowed to be done by skilled personal/technicians.

Error and remedy

The wheel balancer can display the following errors:

Error	Reason
Err -1-	
Err -2-	1. No tire on the balancer / to light tire on the balancer 2. Balancing shaft isn't fix 3. Wheel is not fixed well on the shaft 4. Weak tension on the belt
Err -3-	To big unbalance
Err -4-	Damaged sensor
Err -5-	Wheel guard not closed
Err -7-	Saved data's were delete
Err -8-	Missed 100g weight Damaged sensor Damaged power or main board

Troubleshooting

Errors	Reason	Remedy
Different balancing results ¹	Wheel balancer is not correct fixed on the floor	Check anchoring
	Wrong calibration	Make calibration newly
	Balancing shaft not fix	Check fixation of balancing shaft
	Shaft deformed	Check balancing shaft
	Piezo transducer not fix respectively defect	Check fixation of piezo transducer or exchange
	Rim is not clean or deformed	Check the rim
Buttons do not react	Circuit board button is not connected to the control board or cable connection is defect	Check the connections as well as the line
Motor / Electric		
No motor braking respectively only sporadic	Brake resistor defect respectively not connected	Check brake resistor respectively connection
Motor makes noise	Brake resistor defect respectively not connected	Check brake resistor respectively connection
	Main board defect	Contact the ATH-Service
	Capacitor defect or not connected	Check capacitor respectively connection
Circuit breaker blows	Main switch of machine is not correctly connected or there is a contact fault	Check the electrical connections
	Main board is defect	Contact the ATH-Service

¹Further reasons for „incorrect“ balancing results:

- Using of different adaptors and thus resulting clamping errors.
- By using of adaptors pay urgently attention to the mounting instructions.
- By clamping with cones on a worn centre hole of the rim there can be a difference of up to 10 g.
- The reason for an unbalance of the wheel on the vehicle can be an unbalance on the brake drum respectively on the brake disc or worn fixing bores in the rim respectively in the brake. In such a case, a readjustment is recommendable without taking off the wheel.

Maintenance and service instructions

Adjustment of drive belt tension

1. Take off carefully the cover (weights rack).
2. Loosen the fixing screws of the motor.
3. Slide the motor with the clamping screw, thus pay attention to the correct belt tension.
4. Tighten the fixing screws of the motor again.
5. Make a test run thus pay attention to that the belt does not drop down lateral.
6. Mount the cover again.

Changing fuses

1. Take off carefully the cover (weights rack).
2. Take out the fuse from the power supply board.
3. Exchange the new fuse with the old one, thus only use fuses with the same values.

If the error exists further, please contact the ATH-Service.

DECLARATION OF CONFORMITY

Declaration of conformity

For
Wheel balancer

The following EG-directives are considered:

The following harmonized standards are applied:

Manufacturer:

Institute of Quality:

Reference number for the technical data:

Number of the certificate:

Herewith we confirm that the above-named machines are according to the named EC-directives.

ATH-Heinl GmbH &Co. KG
Kauerhofer Street 2
D-92237 Sulzbach-Rosenberg
GERMANY
in June 2014



Type
ATH W42

2006/42/EC (Machine-Directive)

EN ISO 12100:2010
EN 60204-1:2006/AC:2010

ATH-Heinl GmbH &Co. KG
Kauerhofer Street 2
92237 Sulzbach-Rosenberg
GERMANY

SGS Supervice Gözetme Etüd Kontrol Servisleri A.S.
Baglar Max. Osmanpasa Cad. No. 95
Is Istanbul Plaza, A Girisi
Günesli 34209 Istanbul
TURKEY

TCF-MD-140526-048

0263/IN-IST-14
502756/AOO/AKC
(OUCE 141003)



Hans Heinl (General Manager)
ATH-Heinl GmbH & Co. KG

BY ALTERATIONS AND / OR CHANGES IN THE MACHINE IS THE CE TEST OUT FORCE AND LIABILITY EXCLUDED.

WARRANTY NOTE

Dealer address:	Customer address:
Company (eventually Customer Number)	Company (eventually Customer Number)
Contact person	Contact person
Street:	Street:
ZIP code & Town:	ZIP code & Town:
Tel. & Fax:	Tel. & Fax:
e-Mail:	e-Mail:
Manufacturer & model Serial number	Year of manufacture Reference number

Description of the message:

Description of required spare parts:		
Spare part	Article number	Quantity

IMPORTANT NOTES:

Damage caused by improper handling, lack of maintenance or mechanical damage, does not fall into the warranty. For machines that are not installed by a licensed technician from the company ATH, the warranty is limited to the provision of necessary spare parts.

Damages in transit:

- Obvious defect (note on carrier's delivery note, a copy of delivery notes, Photos of the delivery must be sent immediately to ATH-Heinl)
- Latent defect (Shipping damage is discovered upon unpacking the goods, send damage report with pictures within 24 hours to ATH-Heinl)

Place & date

Signature & stamp

Scope of product warranty

- five years on machine structure
- the warranty in the context of conventional circumstances/use for power supplies, hydraulic cylinder and all other wear parts as turntable, rubber plates, ropes, chains, valves, switches and so on is limited to one year
- ATH-Heinl repairs or replaces the returned parts within the warranty time after own examination

The warranty does not extend to ...

- Defects caused by normal wear, misuse, transport damages, improper installation, voltage or lack of required .
- Damages caused by neglect or non-observance of the stated instructions in this user´s manual and / or other accompanying instructions.
- normal wear of single parts which require a service to maintain the product in a safe operation condition.
- each component which was damaged during transport.
- other components which are not explicitly listed but are handled as general wear parts.
- water damages, caused e.g. by rain, excessive humidity, corrosive environment or other contaminants.
- Blemishes that do not affect the function

WARRANTY DOES NOT APPLY WHEN WARRANTY CLAIM HAS NOT BEEN SENT TO ATH-HEINL.

It should be noted that any damages and malfunctions caused by non-observance of maintenance and adjusting works (according to user´s manual and/or instruction), faulty electrical connections (rotating field, rated voltage, fuse protection) or improper use (overload, outdoor installation, technical changes) are excluded from warranty!



ATH-Heinl

SPARE PART BOOK



4500 kg

Machine

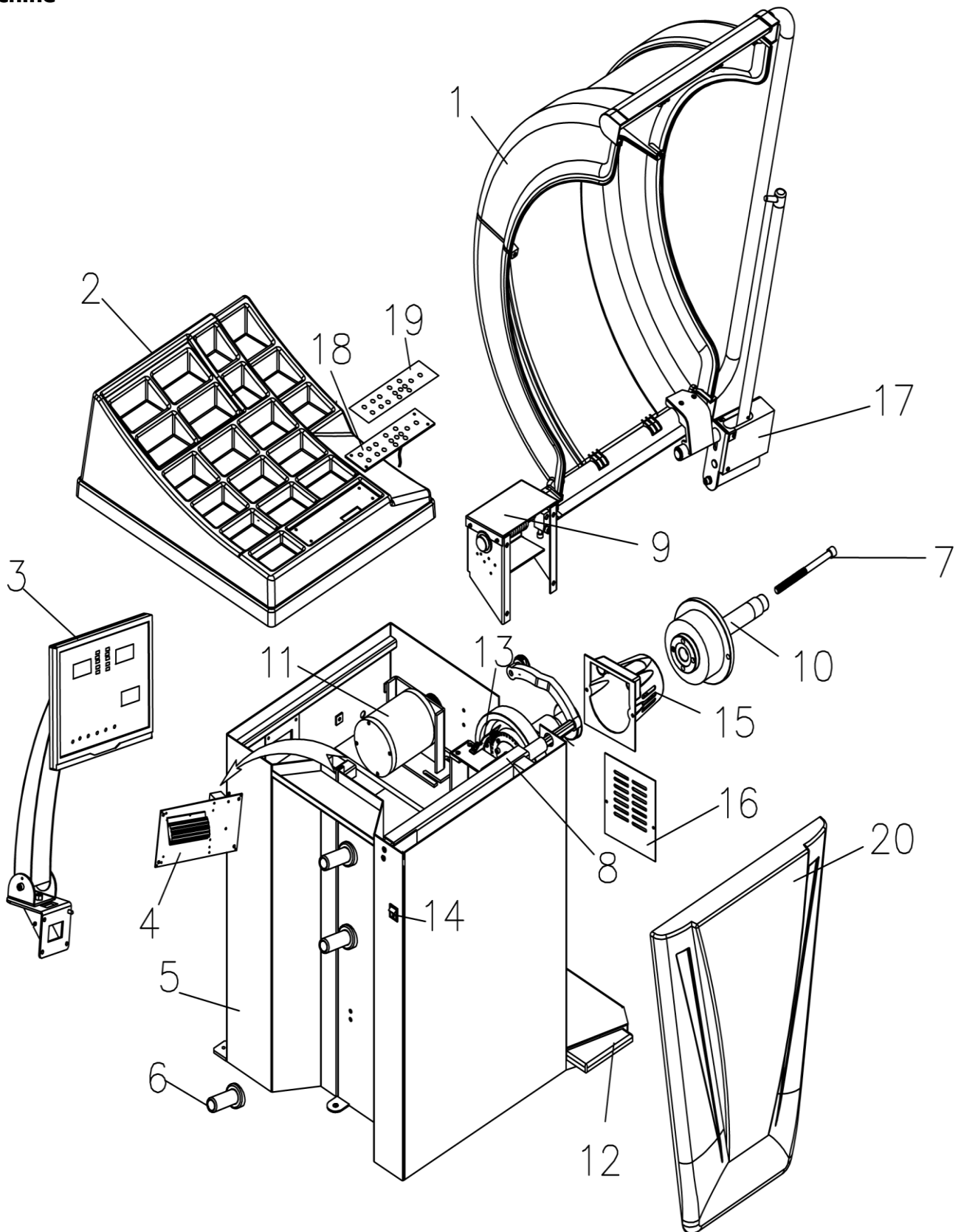

#	ATH #	Reference	Description	Note	x
1	RSB0005	0520230040	Wheel Hood Assembly		1
2	RKA0103	020602066	Weight Tray		1
3	RDA0001	0520211070	Display Assembly		1
4	RSP0002	0520210010	Power Board		1
5	RGE0003	0530203520	Cabinet		1
6	RKH0085	020601008	Cone Handle		3
7		030201172	SHCS	M14x60	1
8	RMA0001	0520204020	Distance Arm Assembly		1
9	RSM0007	0520202020	Hood Mounting Assembly		1
10	RGW0062	0520201060	Main Shaft/Spindle		1
11	RMO0755	0520212010	Motor		1
12	RBM0001	0520206010	Braking System		1
13	RRP6000	0520215020	Encoder		1
14	RHS0001	0520216030	ON/OFF Switch		1
15	RRB7001	0520229020	Laser/LED Light		1
16	RGE0002	0530203214	Cabinet Side Metal Cover		1
17	RMF0115	0520205010	External Gauge		1
18	RTP0172	021101012	Press Key Board		1
19	RSF1100	021101020	Press Key Panel		1
20	RAB0015	020602075	ATH Front plastic cover		1

Display

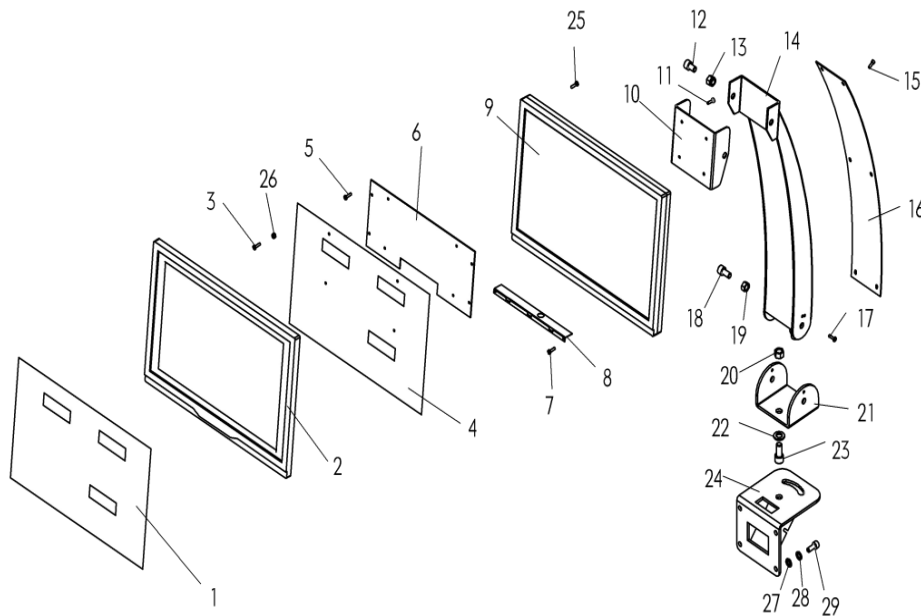

#	ATH #	Reference	Description	Note	x
1	RSF0155	020601188	Display Panel; 15S		1
2	RKA0105	020601194	Display Front Cover	15S1 convex	1
3		030204001	Cross recessed pan head screw	M3x16 GB/T 818-2000	4
4	RDP7000	021006035	Computer/Display Board		1
5		030204001	Cross recessed tapping screw	ST2.9x8 GB 845-1985	4
6	RKP0108	0530211214	Display Liner		1
7		030204001	Cross recessed tapping screw	ST2.9x8 GB 845-1985	2
8	RDT0931	0530211213	Display Stem Sheet		1
9	RKA0106	020601194	Display Back Cover	15S1	1
10	RHM1094	0530211208	Display Connect Plate		1
11		030201337	Cross recessed pan head screw	M4x16 GB/T 818-2000	1
12		030201082	SHCS	M10X20 GB/T 70.1-2000	2
13		030301055	Prevailing torque type nut (with non-metallic insert)	GB/T 889.1-2000 M10	2
14	RHM1095	0530211200	Display Support		1
15		030201004	SHCS	M4X12 GB/T 70.1-2000	6
16	RHM1096	0530211209	Display Support Cover		1
17		030201338	Cross recessed pan head screw	M4x20 GB/T 818-2000	2
18		030201082	SHCS	M10X20 GB/T 70.1-2000	2
19		030301003	Hex Nut	M10 GB/T 41-2000	2
20		030301004	Hex Nut	M12 GB/T 41-2000	2
21	RHM1097	0530211264	Display Support Rotation Basement		1
22		030501007	Washer Flat	12mm GB/T 96.1-2002	2
23		030201112	SHCS	M12x30 GB/T 70.1-2000	2
24	RHM1098	0530211205	Display Support Connect Basement		1
25		030204004	Cross recessed tapping screw	ST2.9x12 GB 845-1985	2
26		030301013	Hex Nut	M3 GB/T 41-2000	12
27		030501005	Washer; Flat	8mm GB/T 96.1-2002	4
28		030502005	Washer; Spring	8mm GB/T 93-2002	4
29		030201063	SHCS	M8x20 GB/T 70.1-2000	4

Accessory

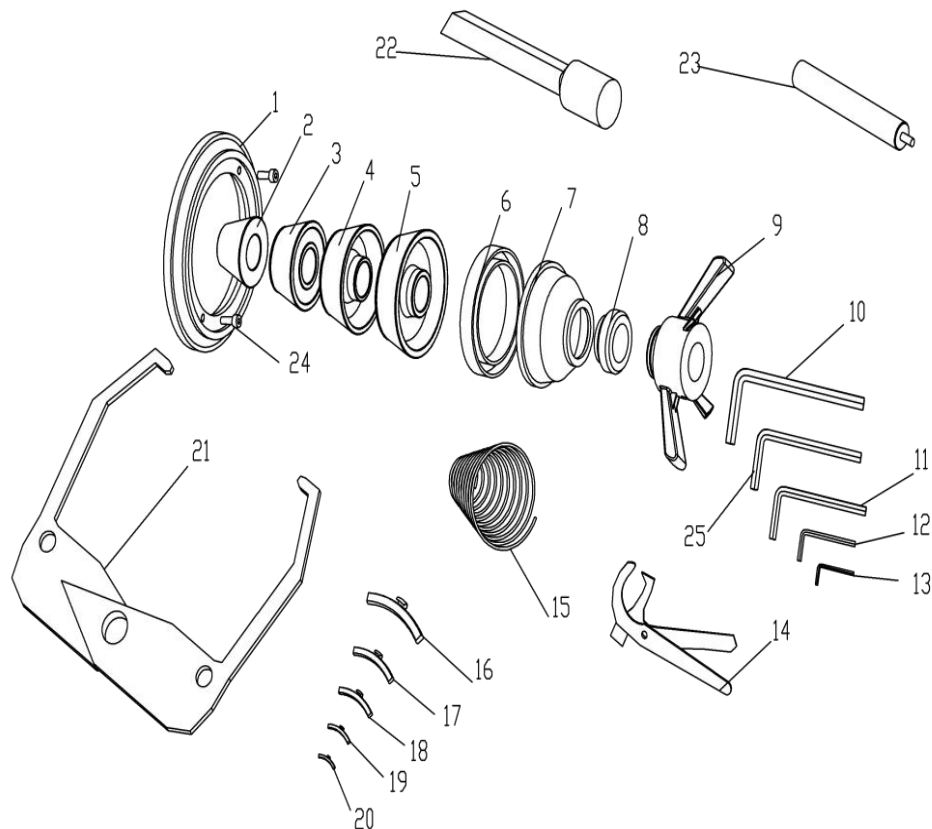

#	ATH #	Reference	Description	Note	x
1	RAF0033	0530201001	Spacer Ring		1
2	RKO0085	0530201008	Cone	45-75 mm	1
3	RKO0086	0530201010	Cone	70-90 mm	1
4	RKO0087	0530201011	Cone	88-110 mm	1
5	RKO0088	0530201012	Cone	105-130 mm	1
6	RGL0065	020101001	Quick Nut Cup Cover		1
7	RDH0034	020601001	Quick Nut Cup		1
8	RKE0192	020601002	Quick Nut Cover		1
9	RSM0199	020601086	Quick Nut	40mm	1
10	RIS0060	022102001	Allen Wrench	12mm	1
11	RIS0063	022102002	Allen Wrench	6mm	1
12	RIS0065	022102003	Allen Wrench	4mm	1
13	RIS0066	022102004	Allen Wrench	3mm	1
14	RGZ0057	022102005	Weight Hammer		1
15	RSF0208	020701019	Mounting Spring	Ø 40mm	1
16	RPG0195	022102006	Weight	100g	1
17	RPG0196	022102010	Weight	50g	1
18	RPG0197	022102011	Weight	35g	1
19	RPG0198	022102013	Weight	10g	1
20	RPG0199	022102027	Weight	5g	1
21	RFL0038	020601004	Wheel Calliper		1
22	152004-05	020601105	Weight Shovel		1
23	RMF0116	0530210003	External Gauge Calibration Kit	OPTIONAL	1
24	HIS2535	030201064	SHCS	M8x25 GB/T 70.1-2000	12
25	RIS0062	022102035	Allen Wrench	8mm	1

Hood Mounting

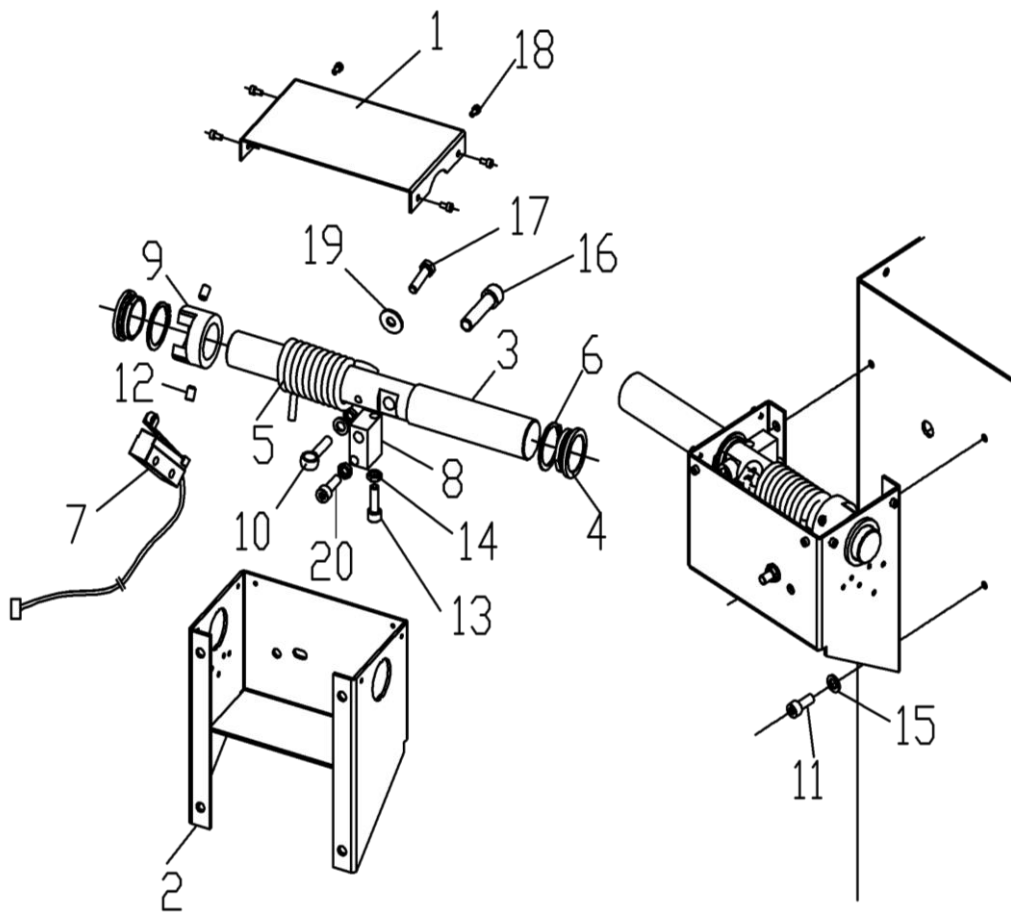

#	ATH #	Reference	Description	Note	x
1	RSM0001	0530208004	Hood Mounting Assembly Cover		1
2	RSM0002	0530208001	Hood Mounting Assembly Bracket		1
3	RSM0003	0530208008	Hood Rotating Shaft		1
4	RSM0004	020601035	Hood Shaft Bushing		2
5	RSM0005	020703001	Hood Spring		1
6		030604115	Snap Ring	38mm GB 894.2-86	2
7	RMS6000	021006031	Hood Switch	V-156-1C25	1
8	RSM0006	0530208002	Hood Cam Stop		1
9	RSM0007	020601034	Hood Cam		1
10	RSM2001	021301004	Adjustable Eye Bolt		1
11		030201063	HHB	M8x20 GB/T 5783-2000	4
12		030202025	Hexagon socket set screw	M8x12 GB/T 77-2000	2
13		030201064	SHCS	M8x25 GB/T 70.1-2000	1
14		030301002	Nut	M8 GB/T 41-2000	2
15		030501005	Washer; Flat	8mm GB/T 95-2002	4
16		030201114	SHCS	M12x40 GB/T 70.1-2000	1
17		030101506	HHB; Full tread	M8x30 GB/T 5783-2000	1
18		030201002	SHCS	M4x8 GB/T 70.1-2000	6
19		030501105	Washer; Wide brim	8mm GB/T 96.2-2002	1
20		030201067	SHCS	M8x40 GB/T 70.1-2000	1

Hood

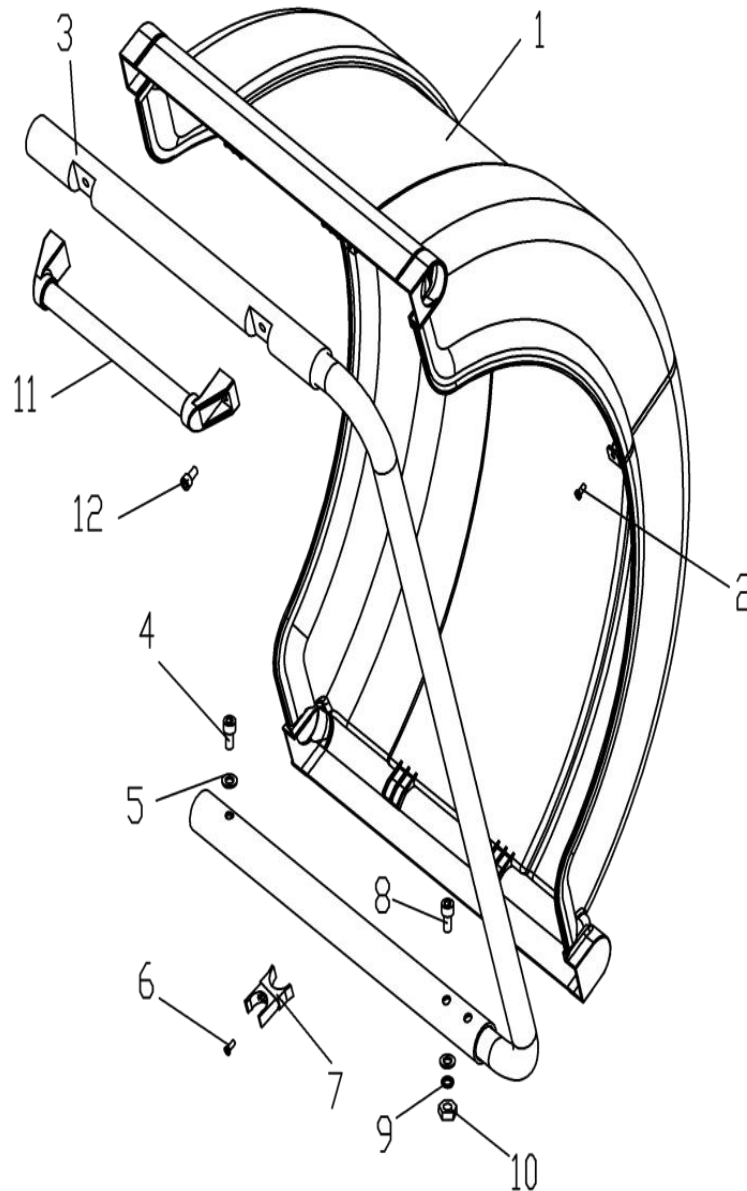

#	ATH #	Reference	Description	Note	x
1	RSB0006	020602029	Wheel Hood Cover; Folded		2
2		030201364	Cross recessed pan head screw	M5x12 GB/T 818-2000	2
3	RSB0007	0530205035	Wheel Hood Support		1
4		030201084	SHCS	M10x30 GB/T 70.1-2000	1
5		030501006	Washer; Flat	10mm GB/T 95-2002	3
6		030201337	Cross recessed pan head screw	M4x16 GB/T 818-2000	1
7	RSB0008	020601049	External Gauge Clip	OPTIONAL	1
8		030201092	SHCS	M10x70 GB/T 70.1-2000	2
9		030502006	Washer; Spring	10mm GB/T 93-1987	2
10		030301003	Nut	M10 GB/T 41-2000	2
11	RSB0004	020601196	Wheel Hood Handle		1
12		030201063	SHCS	M8x20 GB/T 70.1-2000	2

Motor

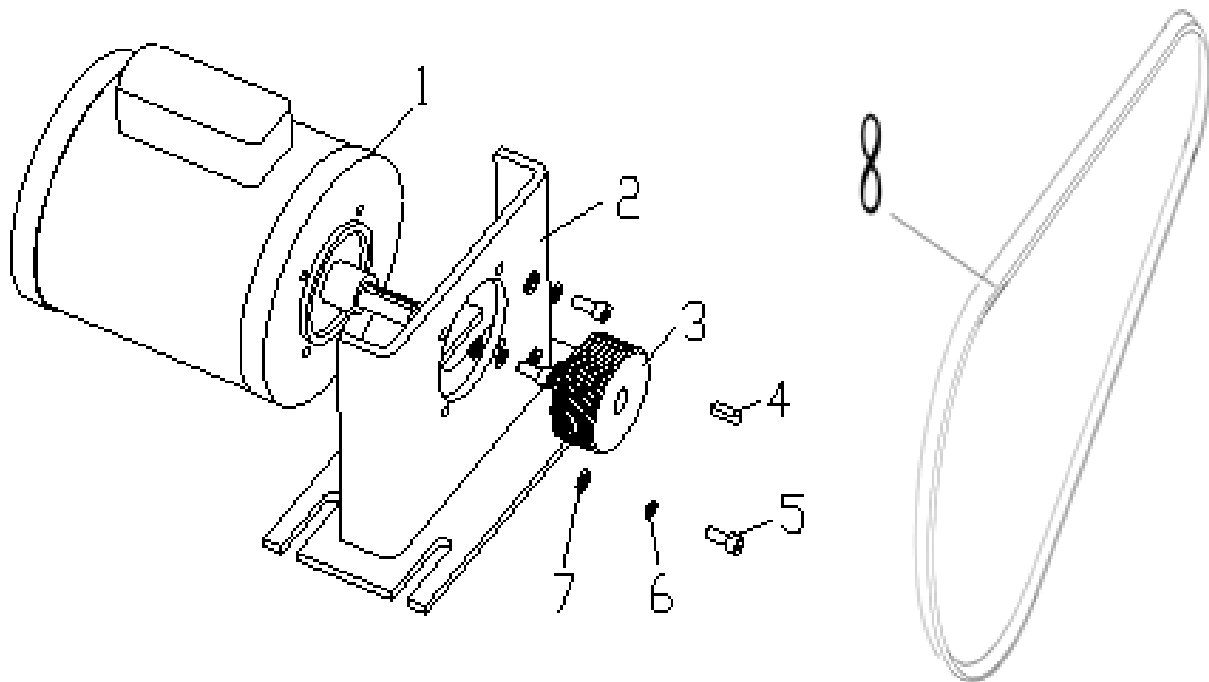

#	ATH #	Reference	Description	Note	x
1	RM00755	020401009	Motor	JY7116 / 220V	1
2	RMH0123	0530206002	Motor Basement		1
3	RRR0134	0530206003	Motor Belt Pulley		1
4		030701010	Key	5x5x30 GB/T 1096-1979	1
5		030201043	SHCS	M6x16 GB/T 70.1-2000	4
6		030502004	Washer; Spring	6mm GB/T 93-1987	4
7		030501004	Washer; Flat	6mm GB/T 95-2002	4
8	RRR0133	020403001	Motor Belt	4PJ965	1

Main shaft

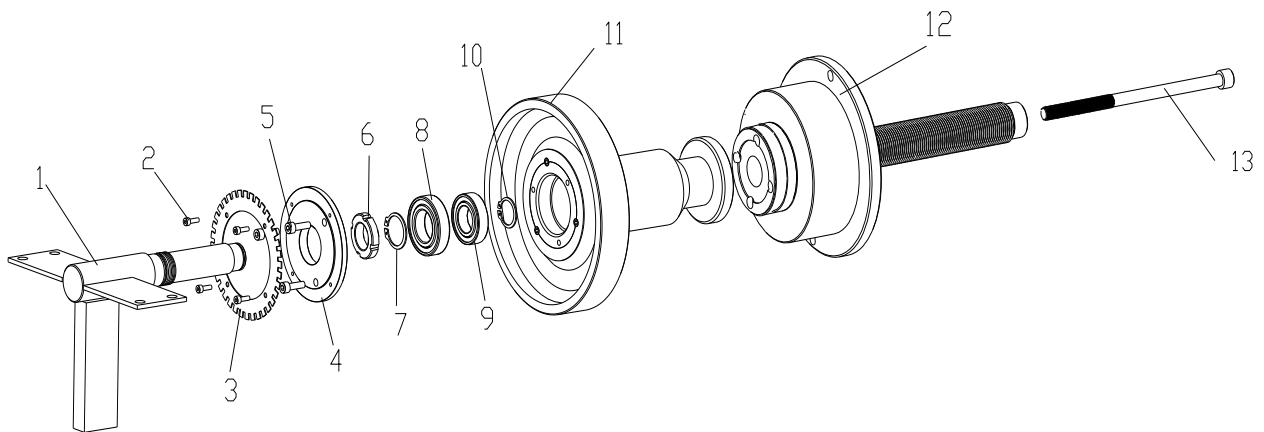

#	ATH #	Reference	Description	Note	x
1	RWA0001	0530207004	Deformation of Beams		1
2		030201004	SHCS	M4x12 GB/T 70.1-2000	4
3	RWZ0001	0530207009	Tooth	64T	1
4	RWA0002	0530207005	Bear Cover		1
5		030201044	SHCS	M6x20 GB/T 70.1-2000	3
6		030303101	Nut Round	M30x1.5 GB/T 812-1988	1
7		030604023	Snap Ring	30mm GB 894.1-86	1
8	RWL0845	030802002	Bearing	6006 GB/T 276-94	1
9	RWL0184	030802001	Bearing	6005 GB/T 276-94	1
10		030604105	Snap Ring	25mm GB 894.2-86	1
11	RWW0214	0530207006	Main Shaft		1
12	RGW0062	0530207054	Threaded Shaft/Spindle		1
13	RGW0063	030201172	SHCS	M14x260 GB/T 70.1-2000	1

Sensor

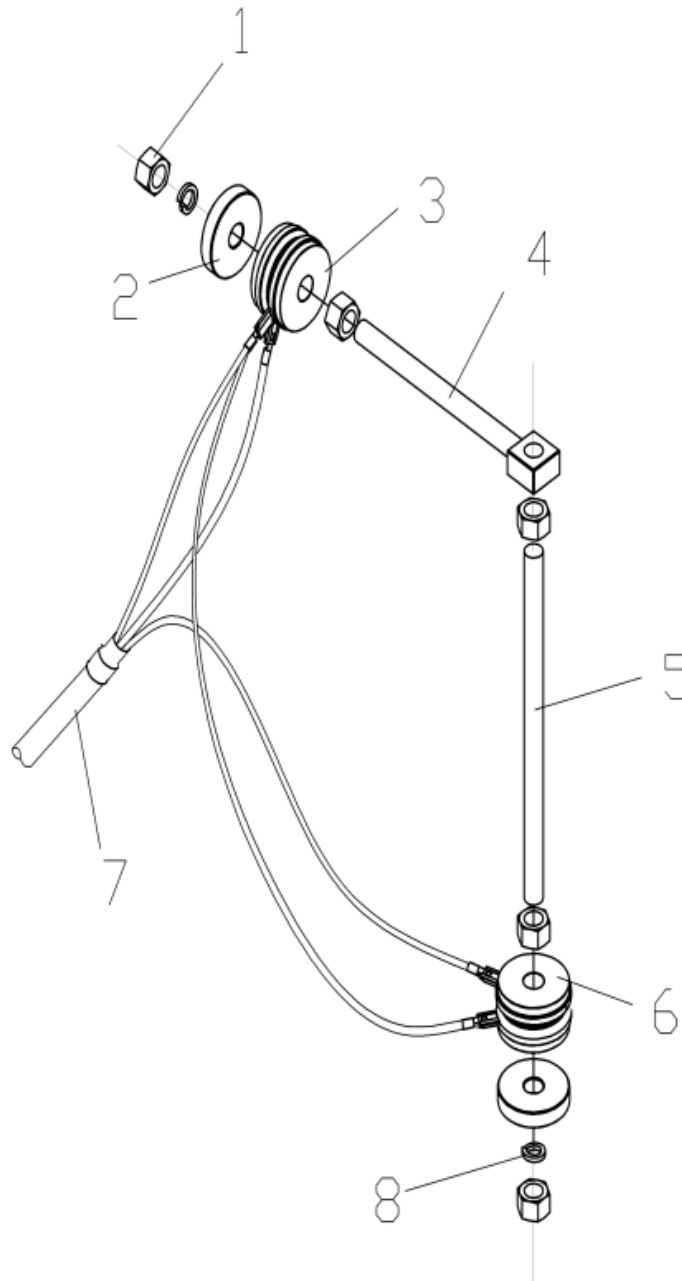

#	ATH #	Reference	Description	Note	X
1		030301003	Nut	M10 GB/T 41-2000	5
2		0530207043	Sensor flat washer		2
3	RPA0128	021006032	Piezo Sensor; Horizontal	Ø10 + Ø 10 / 3x0.75mm ² x1.5m	1
6		021301007	Sensor Horizontal Shaft		1
7		021301008	Sensor Vertical Shaft		1
4	RPA0129	021006033	Piezo Sensor; Vertical		1
5	RPA0130	020402015	Sensor Wire		1
8		030502006	Washer; Spring	10mm GB/T 93-1987	2

Encoder

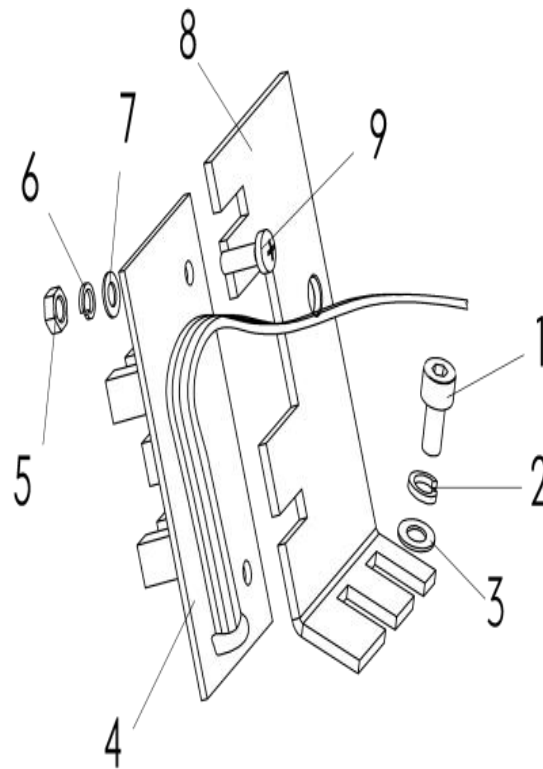

#	ATH #	Reference	Description	Note	x
1		030201002	SHCS	M4x8 GB/T 70.1-2000	2
2		030502002	Washer; Spring	4mm GB/T 93-1987	2
3		030501002	Washer; Flat	4mm GB/T 95-2002	2
4	RRP0138	021003004	Encoder Board	64T	1
5		030301101	Nut	M3 GB/T 6170-2000	2
6		030502001	Washer; Spring	3mm GB/T 93-1987	2
7		030501001	Washer; Flat	3mm GB/T 95-2002	2
8	RRP0139	0530207003	Encoder Board Support		1
9		030201265	Cross recessed	M3x10 GB/T 818-2000	2

Brake

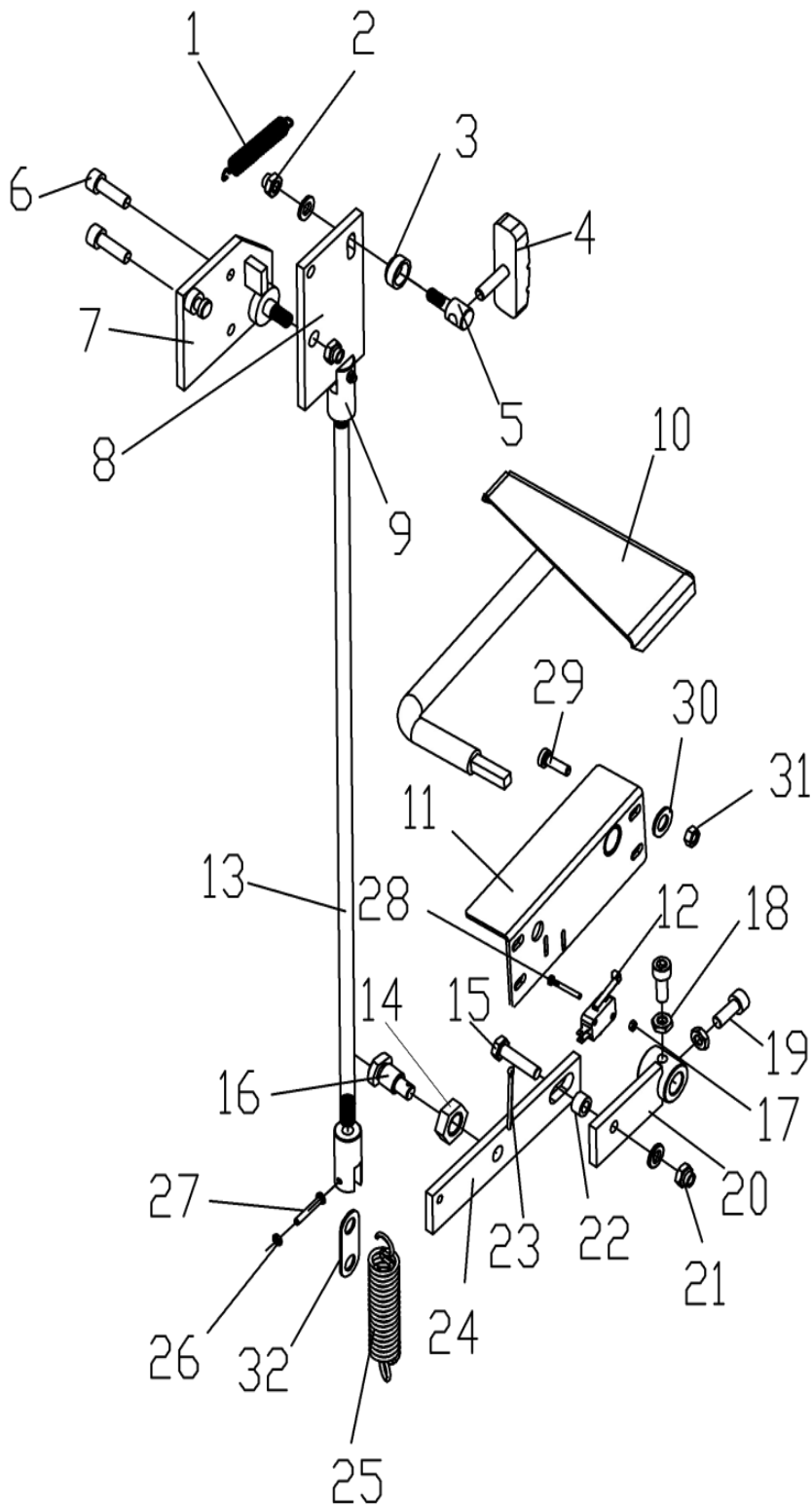

#	ATH #	Reference	Description	Note	x
1	RFB0001	020702001	Upper Braking Return Spring		1
2		030301082	Nut	M6 GB/T 6182-2000	1
3	RBA0012	0530202002	Brake Pad Spacer		1
4	RBK1000	020101002	Brake Pad		1
5	RBA0002	0530202001	Brake Pad Bracket		1
6		030201042	SHCS	M6x12 GB/T 70.1-2000	2
7	RBA0003	0530202003	Brake Fix Mounting Plate		1
8	RBA0004	0530202004	Brake Movable Mounting Plate		1
9	RBA0005	0530106010	Brake Rod Connector		2
10	RBP0001	0530202009	Brake Pedal Weldment		1
11	RBA0006	0530202022	Brake Pedal Bracket		1
12	RMS6001	021006031	Brake Switch		1
13	RBZ0001	0530202005	Braking Rod		1
14		030301138	Nut	M12 GB/T 6172.1-2000	1
15		030101024	HHB	M6x25 GB/T 5780-2000	1
16	RBA0007	0530202012	Brake Fix Axle		1
17		030301101	Nut	M3 GB/T 6170-2000	2
18		030301105	Nut	M6 GB/T 6170-2000	2
19		030201043	SHCS	M6x16 GB/T 70.1-2000	2
20	RBA0008	0530202008	Brake Pedal Link		1
21		030301105	Nut	M6 GB/T 6170-2000	3
22	RBA0009	0530202007	Brake Linkage Bushing		1
23		030903006	Slick pin	2x20 GB/T 91-2000	1
24	RBA0010	0530202006	Brake Rod Link		1
25	RFB0002	020702002	Lower Braking Return Spring		1
26		030301102	Nut	M4 GB/T 6170-2000	2
27		030201006	SHCS	M4x20 GB/T 70.1-2000	2
28		030201269	Cross recessed pan head screw	M3x20 GB/T 818-2000	2
29		030201044	SHCS	M6x20 GB/T 70.1-2000	4
30		030501004	Washer; Flat	6mm GB/T 95-2002	4
31		030301105	Nut	M6 GB/T 6170-2000	4
32	RBA0011	0530106033	Brake Rod Connector Linkage		1

Power board

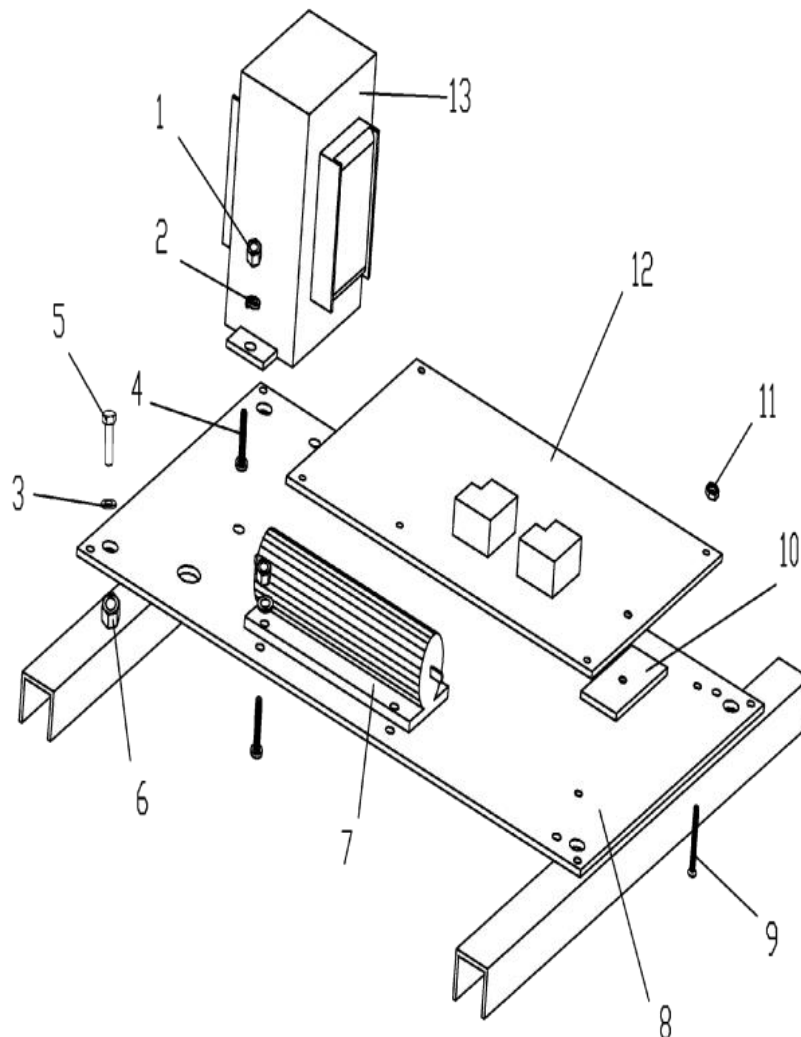

#	ATH #	Reference	Description	Note	x
1		030301103	Nut	M4 GB/T 6170-2000	4
2		030502002	Washer; Spring	4mm GB/T 93-1987	4
3		030502004	Washer; Spring	6mm GB/T 95-2002	4
4		030201337	Cross recessed pin head screw	M4x16 GB/T 818-2000	4
5		030101022	HHB	M6x16 GB/T 5780-2000	4
6		030301106	Nut	M8 GB/T 6170-2000	4
7	RWI0183	021002001	Resistance	100W/15Ω RXG-100-15RJ	1
8	RSP0170	0530206001	Power Board Liner		1
9		030201614	Cross recessed socket screw	M3x25 GB/T 819.1-2000	5
10	RSP0171	0530206056	Air-Cooling Fin		1
11		030301101	Nut	M3 GB/T 6170-2000	15
12	RSP0169	021003003	Power Board		1
13	RTR0174	020404006	Transformer	220V~Double 9V 25W	1

Distance arm

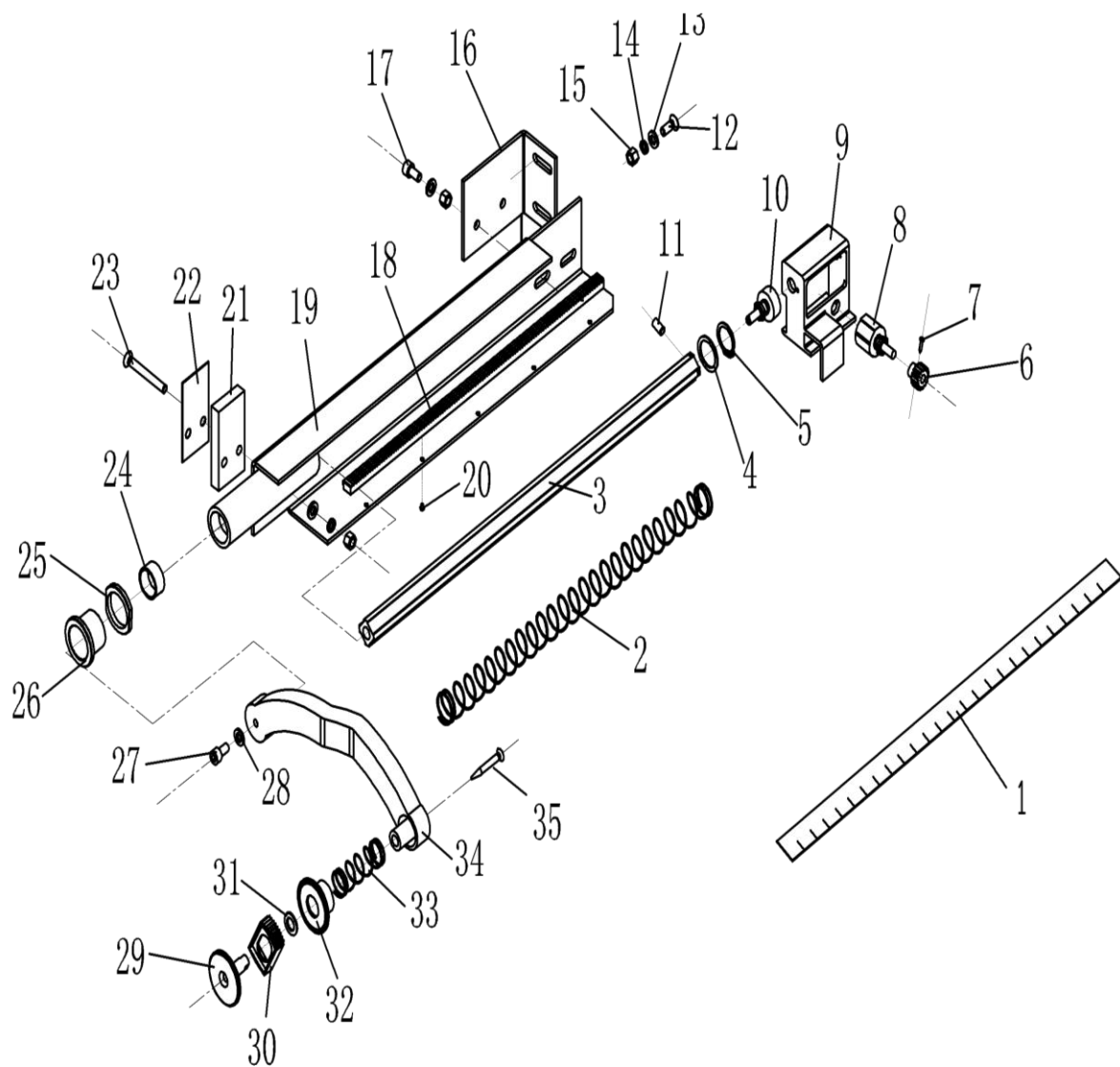

#	ATH #	Reference	Description	Note	x
1	RAL0001	020801005	Distance Arm Sticker		2
2	RFA0001	020701005	Distance Arm Spring		1
3	RAL0002	0530204010	Distance Arm Rod		1
4		0530204008	Distance Arm Rod Washer		1
5		030604101	Snap Ring	20mm GB/T 894.2-86	1
6	RGA0001	0530204013	Distance Arm Gear		1
7		030204002	Cross recessed tapping screw	GB/T845-1985 ST2.9x9.5	1
8	RPO0131	021006025	Wheel Distance Potentiometer; Double Round	R10KL.25	1
9	RPH0001	0530204012	Distance Arm Slide Block		1
10	RPO0130	021006024	Wheel Distance Potentiometer; Single Round	CPP22A1S20B103	1
11		030202011	Hexagon socket set screw	GB/T 77-2000 M4x4	1
12		030201443	Cross recessed pan head screw	M6x20 GB/T819.1-2000	2
13		030501004	Washer; Flat	6mm GB/T 95-2002	6
14		030502004	Washer; Spring	6mm GB/T 93-1987	6
15		030301011	Nut	M6 GB/T 41-2000	6
16	RPH0002	0530204022	Distance Arm End Metal Plate		1
17		030201043	SHCS	M6x16 GB/T70.1-2000	2
18	RGA0002	0530204009	Distance Arm Gear Rail		1
19	RAA0001	0530204004	Distance Arm Basement		1
20		030204001	Cross recessed tapping screw	GB/T845-1985 ST2.9x6.5	5
21	RPH0003	0530204018	Distance Arm Pad		1
22	RPH0004	0530204024	Distance Arm Adjustable Spacer		1
23		030201444	Countersunk Flat Phillips Head Screw	M6x40 GB/T819.1-2000	2
24	RBA0001	030818001	Distance Arm Sleeve		2
25	RBA0002	0530214002	Distance Arm Sleeve Nut		2
26	RBA0003	0530214001	Nut Bush		1
27		030201043	SHCS	M6x16 GB/T70.1-2000	1
28		030501004	Washer; Flat	6mm GB/T 95-2002	1
29	RES0002	020601076	Distance Arm Head Pivot Bushing		1
30	RSS0001	020602040	Distance Arm Head Weight Holder		1
31	RBS2000	030501007	Washer; Flat	12mm GB/T 95-2002	1
32	RKP0001	020601069	Distance Arm Head Bushing		1
33	RSF2000	020701005	Distance Arm Head Spring		1
34	RGM0001	020601104	Distance Arm Head Connect Rod		1
35	RBS2001	030204100	Cross recessed tapping screw	ST4.9x32 GB/T845-1985	1

Laser

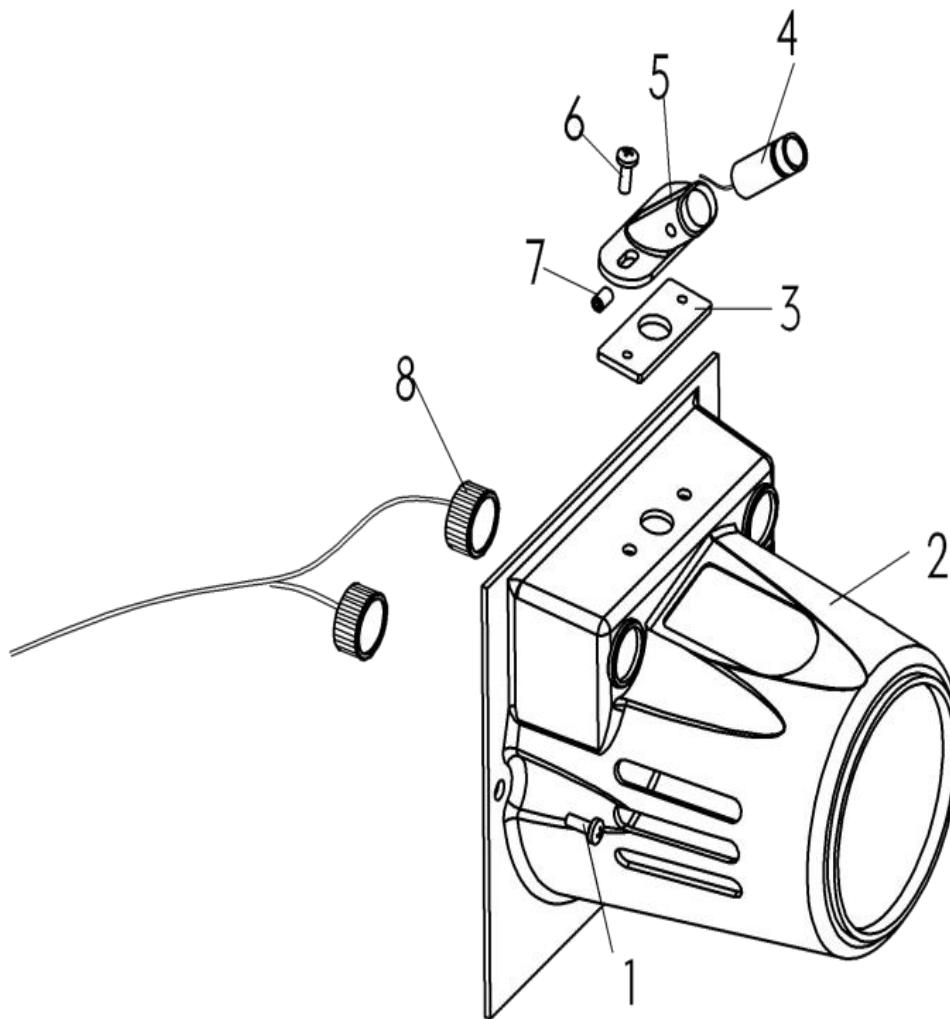

#	ATH #	Reference	Description	Note	x
1		030201335	Cross recessed pan head screw	M4x12 GB/T 818-2000	2
2	RKA0104	0530206034	Threaded Shaft Plastic Cover		1
3	RLG0001	0530206033	Laser Basement Plate		1
4	RLA0001	02106035	Laser Line Optical Transmitter	Ø12x35—5V	1
5	RLA0002	0530206032	Laser Basement		1
6		030201335	Cross recessed pan head screw	M4x12 GB/T 818-2000	2
7		030202301	Hexagon tapper head set screw	M5x5 GB/T 78-2000	1
8	RRB7000	020402010	Weight Indicator Light		1

Computer board

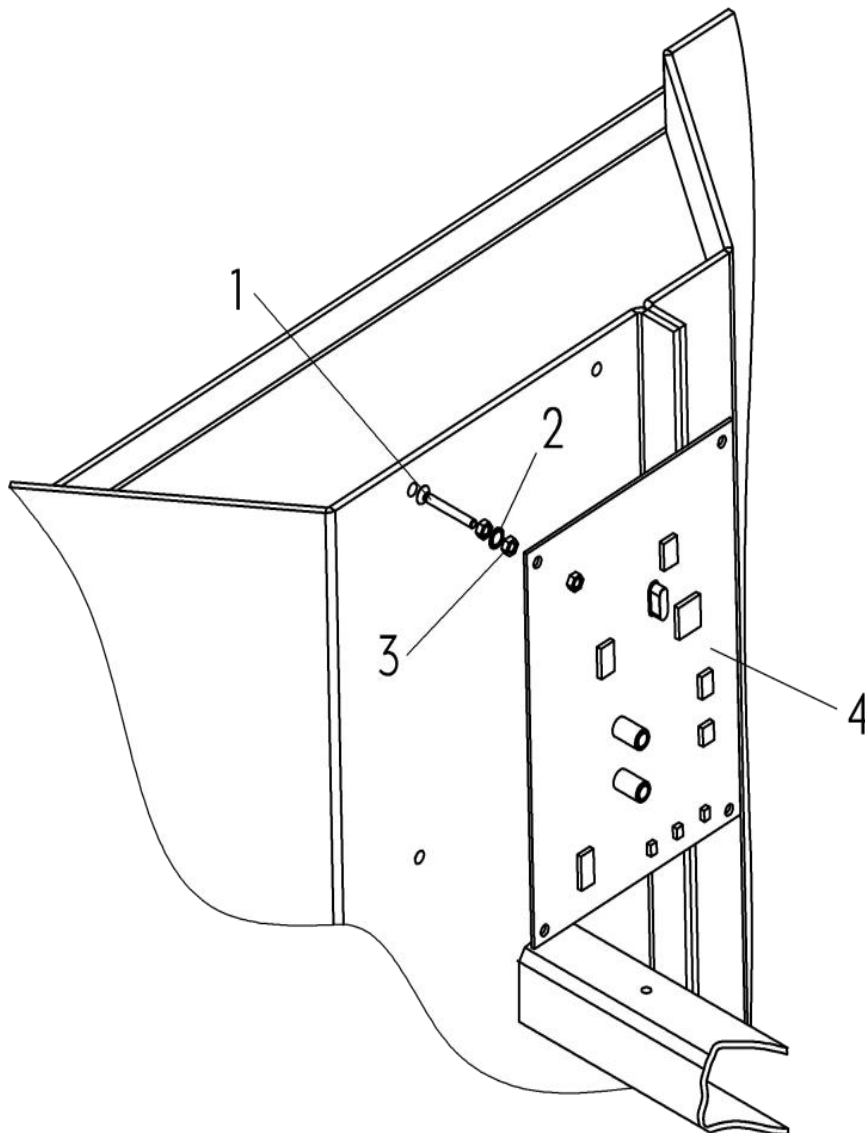

#	ATH #	Reference	Description	Note	x
1		030201614	Screw	GB/T 819.1-2000 M3x25	4
2		030502001	Spring washer	GB/T 93-1987 3	8
3		030301101	Nut	GB/T 6170-2000 M3	12
4	RSP0168	021003016	Computer board		1

ATH-Heinl GmbH & Co.KG

Kauerhofer Str. 2
D-92237 Sulzbach-Rosenberg
GERMANY

Tel: +49 (0)9661 87764 00

Fax: +49 (0)9661 87764 01

info@ath-heinl.de

www.ath-heinl.de



Mitglied im Bundesverband der Hersteller und Importeure von Automobil-Service Ausrüstungen e.V.
Member of Bundesverband ASA (Association of producer and importers of automobile-service equipment)
Membre de la Bundesverband ASA (Fédération allemande des producteurs et importateurs d' équipement pour garage automobile)



www.ath-heinl.de